

# **Liebert ITA UPS 16kVA/20kVA**

## **User Manual**

Version            V1.0  
Revision date    January 26, 2010  
BOM                31011782

---

Emerson Network Power provides customers with technical support. Users may contact the nearest Emerson local sales office or service center.

Copyright © 2010 by Emerson Network Power Co., Ltd.

All rights reserved. The contents in this document are subject to change without notice.

Emerson Network Power Co., Ltd.

Address: No.1 Kefa Rd., Science & Industry Park, Nanshan District 518057, Shenzhen China

Homepage: [www.emersonnetworkpower.com.cn](http://www.emersonnetworkpower.com.cn)

E-mail: [support@emersonnetwork.com.cn](mailto:support@emersonnetwork.com.cn)

## Safety Precautions

This manual contains the information concerning the installation and operation of Liebert ITA 16kVA/20kVA UPS (hereinafter referred to as UPS).

Please carefully read this manual prior to installation.

The UPS must be installed, commissioned and serviced by engineers designated by the manufacturer or its agent. Failure to observe this could result in personnel safety risk, UPS malfunction and invalidation of warranty.

The UPS has been designed for commercial and industrial use only, and is not recommended for use in life support applications.

This is a Class A UPS product. In a residential environment, this product may nevertheless cause radio interference, in which case, the user may be required to take additional measures.



Conformity and standards

The UPS complies with 2006/95/EC, 93/68/EEC (LV Safety) and 2004/108/EC (EMC), with Australia and New Zealand EMC Framework (C-Tick) and with the following product standards for UPS:

\* IEC62040-1-1: General and safety requirements for use in operator access area

\* IEC62040-2: EMC requirements, Class C2 compliant

\* IEC62040-3: Performance requirements and test methods

The UPS installation should follow the above instructions and use the accessories specified by manufacturer.



Warning: High Leakage Current

Earth connection is essential before connecting the input power supply (AC mains and battery included). This equipment must be earthed in accordance with the local electrical codes.

Earth leakage current ranges from 3.5mA to 1000mA.

Transient and steady-state earth leakage currents, which may occur when starting the equipment, should be taken into account when selecting instantaneous residual current circuit breaker (RCCB) or residual current detector (RCD) devices. RCCB must be selected, for it is insensitive to DC unidirectional pulses (Class A) and transient current pulses.

Note that the earth leakage currents of the load will be carried by RCCB or RCD.



Warning: Reflected Protection

The UPS has a zero-voltage contact closure signal available for use with an external automatic circuit breaker (single power supply), to protect against backfeeding voltage through the static bypass circuit. If the installing engineer do not need to use this signal, a label must be added to the switchgear to advise service personnel that the circuit is connected to a UPS system.

The text can be written: ISOLATE THE UNINTERRUPTIBLE POWER SYSTEM BEFORE WORKING ON THIS CIRCUIT.



Maintainable Components

All equipment maintenance and servicing procedures involve internal should be carried out only by trained personnel.

Removal of devices behind the protective cover requires the use of a tool and is restricted to service personnel.

The UPS meets the safety requirements completely in operator access area. Only the service personnel can contact with the hazardous voltage inside the UPS. However, the risk of contacting with these voltages is minimized as the components with hazardous voltage may be contacted only uses a tool to remove the protective cover. No risk exists to any personnel when operating the equipment in normal manner, following the recommended operation procedures.



Battery voltage exceeds 400Vdc

Tools or keys should be used for all batteries maintenance, which should be carried out by trained personnel. Battery use requires special care. After the battery is connected, the voltage of the battery terminal will exceed 400Vdc, and physical contact would be fatal. Battery manufacturers supply details of the necessary precautions to be observed when working on, or in the vicinity of the battery strings. These precautions should be followed implicitly at all times. Particular attention should be paid to the recommendations concerning local environmental conditions and the provision of protective clothing, first aid and fire-fighting facilities.



# Contents

Chapter 1 Product Introduction.....	1
1.1 Features .....	1
1.2 Model Configuration .....	1
1.3 Appearance And Components .....	2
1.3.1 Appearance.....	2
1.3.2 Components.....	2
1.4 Operating Principle.....	3
1.5 UPS State And Operation Mode .....	3
1.5.1 Normal Mode .....	3
1.5.2 Bypass Mode .....	3
1.5.3 Battery Mode.....	4
1.5.4 ECO Mode (For Single System Only) .....	4
1.5.5 Fault State.....	4
1.6 Specifications .....	5
Chapter 2 Installation .....	6
2.1 Unpacking Inspection .....	6
2.2 Location .....	6
2.2.1 Distribution Room .....	7
2.2.2 Battery Room.....	7
2.2.3 Storage .....	7
2.3 Installation tools.....	7
2.4 Mechanical Installation.....	8
2.4.1 Tower Installation.....	8
2.4.2 Rack Installation .....	9
2.5 External Protective Device .....	10
2.5.1 Rectifier And Bypass Inputting .....	10
2.5.2 Battery Input.....	11
2.5.3 UPS Output.....	11
2.6 Connecting Power Cables.....	11
2.6.1 Cables Selection.....	11
2.6.2 Connecting I/O Cables .....	12
2.6.3 Connecting Battery Cables.....	17
2.7 Connecting Communication Cables .....	18
2.7.1 Connecting Dry Contact Communication Cable .....	18
2.7.2 Connecting USB Communication Cable .....	19
2.7.3 Connecting SNMP Card Communication Cable .....	19
2.8 Parallel System .....	20

2.8.1 Mechanical Installation .....	20
2.8.2 Setting Parallel Addresses .....	21
2.8.3 Connecting Parallel Cables .....	21
2.8.4 Connecting 1 + 1 Parallel POD Cables .....	21
2.9 Common Battery Strings .....	22
2.10 Double Bus System .....	22
2.10.1 System Installation .....	22
2.10.2 External Protective Device .....	23
2.10.3 Power Cables .....	23
2.10.4 LBS Control Cables .....	23
Chapter 3 Operation And Display Panel .....	24
3.1 Introduction .....	24
3.1.1 LED Indicators .....	24
3.1.2 Audible Alarm (Buzzer) .....	24
3.1.3 Control Buttons .....	25
3.1.4 LCD And Menu Buttons .....	25
3.2 LCD Screen Types .....	25
3.2.1 Start Screen .....	25
3.2.2 Primary Screen .....	26
3.2.3 Default Screen .....	26
3.3 Detailed Description Of Menu Items .....	27
3.4 Prompt Window .....	29
3.5 UPS Alarm Message List .....	29
Chapter 4 UPS Operation Instructions .....	32
4.1 UPS Start-up .....	32
4.1.1 Normal Module Start-up Procedure .....	32
4.1.2 Battery Module Start-up Procedure .....	32
4.2 Transferring Procedures Between Operation Modes .....	32
4.2.1 Transferring From Normal Mode To Battery Mode .....	32
4.2.2 Transferring From Normal Mode To Bypass Mode .....	33
4.2.3 Transferring From Bypass Mode To Normal Mode .....	33
4.2.4 Transferring From Normal Mode To Maintenance Bypass Mode .....	33
4.3 Complete Shutdown Procedure .....	33
4.4 EPO Procedure .....	34
4.5 Auto Restart .....	34
4.6 UPS Reset Procedure .....	34
4.7 Language Selection .....	34
4.8 Changing Current Date And Time .....	34
4.9 Control Password .....	35

Chapter 5 Maintenance ..... 36

- 5.1 Fan Maintenance..... 36
- 5.2 Battery Maintenance ..... 36
- 5.3 Cleaning UPS..... 36
- 5.4 Checking UPS State ..... 36
- 5.5 Checking UPS Functions ..... 36

Appendix 1 Battery Module..... 38

Appendix 2 Optional Part List ..... 40



# Chapter 1 Product Introduction

Liebert ITA 16kVA and 20kVA UPS (UPS for short) is an intelligent online UPS system with sine wave output developed by Emerson Network Power Co., Ltd. The UPS provides reliable and high quality AC power to your sophisticated equipment. The UPS adopts modular design, and rack/tower installation can be used depending on your requirements. It is applicable to supplying AC power to small scale computer center, network, communication system, automatic control system and precision instrument.

This chapter gives a brief description of the UPS, including the UPS features, model configuration, appearance, components, operating principle, state, operation mode and specifications.

## 1.1 Features

Liebert ITA 16kVA UPS is compatible with Liebert ITA 20kVA UPS. The UPS features include:

- Compatible with two modes: 3-phase mains output and single-phase mains output. You should check the system wiring and conduct the panel setting manually
- Capable of parallel connection to achieve up to 3 + 1 parallel redundant power supply
- High-frequency double conversion topology structure, with high input power factor, wide input voltage range, and output immune to grid interference, thus adaptable to areas with unstable mains supply
- High power density
- Full digital control technology based on digital signal processor (DSP) to achieve high system reliability with self-protection and fault diagnosis functions
- Intelligent battery management to extend the battery module life
- Operation and display panel with both LCD and LED indication to help you learn about the system operation status and operating parameters
- 3U thickness. Tower installation and rack installation are optional to meet different installation requirements
- Capable of ECO mode, which helps you save energy to the maximum extent
- Flexible network management with Emerson monitoring software
- Fan fault self-inspection and automatic recognition function
- SNMP card optional, providing network communication function
- Capable of connecting multiple battery strings, extending the power supply time of Battery mode

## 1.2 Model Configuration

Two models are available for Liebert ITA 16kVA and 20kVA UPS: UHA3R-0160L, UHA3R-0200L. The description of model configuration is shown in Table 1-1.

Table 1-1 Model configuration

Model	Description
UHA3R-0160L	For single and parallel 1 + 1 system, four battery modules are available; for 1 + 1 parallel system or more, battery connection is required
UHA3R-0200L	For single and parallel 1 + 1 system, four battery modules are available; for 1 + 1 parallel system or more, battery connection is required

## 1.3 Appearance And Components

### 1.3.1 Appearance

The UPS appearance is shown in Figure 1-1.

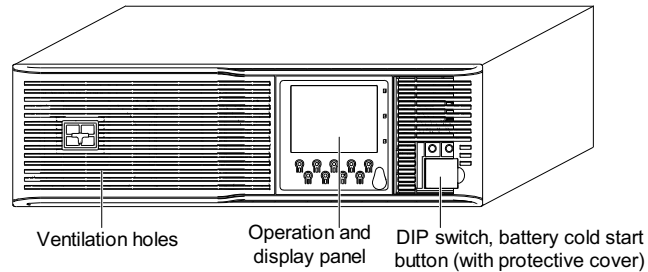



Figure 1-1 UPS appearance

 <span style="font-weight: bold;">Note</span>
Non-authorized personnel are prohibited from opening the UPS chassis cover. Otherwise, electric shock may occur.

### 1.3.2 Components

#### Front panel

As shown in Figure 1-1, the UPS front panel provides the ventilation holes, operation and display panel, DIP switch and battery cold start button (with protective cover). The operation and display panel provides LCD, menu buttons, LED indicators and control buttons. Refer to *Chapter 3 Operation And Display Panel* for details.

#### Rear panel

As shown in Figure 1-2, the UPS rear panel provides the parallel ports, load bus synchronization (LBS) ports, dry contact I/O port, SNMP card port, USB port, I/O terminal block and ventilation holes.

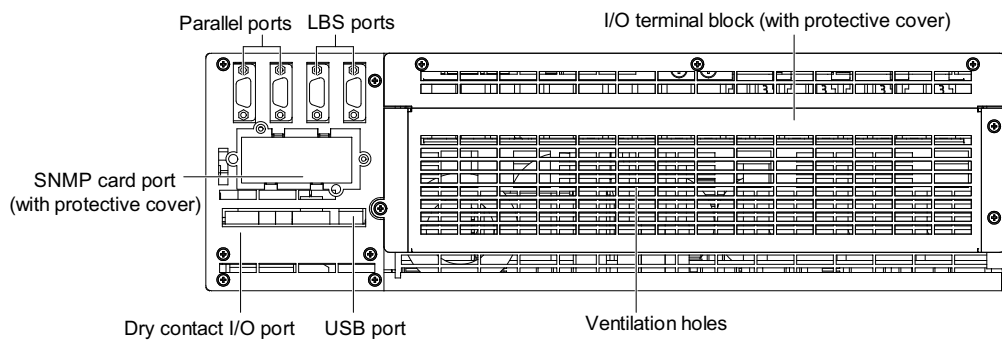

Figure 1-2 UPS rear panel

## 1.4 Operating Principle

The operating principle of the UPS is shown in Figure 1-3.

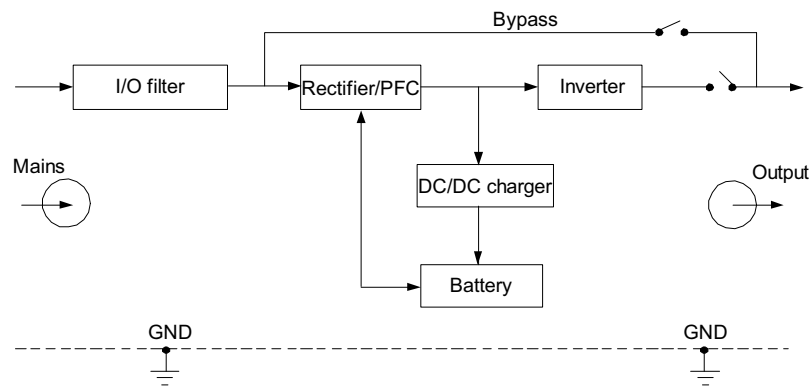

Figure 1-3 Operating principle

1. The UPS is composed of mains input, I/O filter, rectifier/PFC, DC/DC charger, inverter, bypass, battery and UPS output.
2. When the mains is normal, the rectifier will start, and the DC/DC charger will charge the battery strings. Before turning on the UPS, the output voltage is the bypass voltage. After turning on the UPS, the electronic transfer switch connects the inverter to the load, and the mains supplies DC power to the inverter through the rectifier/PFC circuit. The inverter then inverts DC power to pure sine wave AC power and supplies AC power to the load through the electronic transfer switch.
3. When the mains is abnormal, the rectifier/PFC circuit boosts the battery voltage and supplies it to the inverter. The inverter then converts it into pure sine wave AC power, and supplies AC power to the load through the electronic transfer switch.
4. After the mains returns to normal state, the UPS will automatically switch to Normal mode from Battery mode, the mains power supplies DC power to the inverter through the rectifier/PFC circuit, and then the electronic transfer switch supplies DC power to the load.

## 1.5 UPS State And Operation Mode

The UPS state and operation modes include: Normal mode, Bypass mode, Battery mode, ECO mode and Fault state. For the description of indicators in this section, refer to *Chapter 3 Operation And Display Panel* for details.

### 1.5.1 Normal Mode

When the mains input is normal, the load is powered with voltage-stabilizing and frequency-stabilizing power supply by the mains after processing of the rectifier and the inverter, and meanwhile, the operation mode that the charger charges the battery is the Normal mode. In Normal mode, the inverter indicators are on (green).

### 1.5.2 Bypass Mode

If the overload is overtime, inverter or rectifier fails during the UPS operating in Normal mode, the UPS will switch to Bypass mode, and the load is powered by the bypass source, which comes directly from the mains input; if the rectifier is normal, the internal charger will charge the battery. In Bypass mode, the inverter indicators are off.



Note

In the event of the mains failure or mains voltage exceeds the specifications in Bypass mode, the UPS will shut down and stop the output.

### 1.5.3 Battery Mode

Upon mains failure, rectifier overload or mains voltage exceeds the specifications, the rectifier and internal charger will become inoperative, and the battery will supply power to the load through the inverter. The inverter indicators are on and the buzzer alarms, which notifies you that the UPS is in Battery mode.



1. The battery has been fully charged before delivery. However, transportation and storage will inevitably cause some charge loss. Therefore, it is required to charge the battery for eight hours before putting the UPS into operation, so as to ensure the adequate stand time for battery.
2. Battery cold start can also be used to start the UPS from the Battery mode (charged) upon mains failure. Therefore, the battery power supply can be used independently for improving the system availability to some extent.

### 1.5.4 ECO Mode (For Single System Only)

In ECO mode, the load is powered by bypass when the bypass voltage is normal, and the load is powered by inverter when the bypass voltage is abnormal. ECO mode is an energy-saving operation mode. For some power equipment that insensitive to power grid quality, you can use the ECO mode for power supply through bypass to reduce the power loss.



1. In ECO mode, if the bypass failure or bypass voltage is abnormal when the output is not overload, the UPS will switch to Normal mode. However, if the bypass failure or bypass voltage is abnormal when the output is overload, the UPS will not switch to Normal mode, but shut down the bypass.
2. In ECO mode, the efficiency of the UPS is up to 98%.

### 1.5.5 Fault State

In Normal mode, the UPS will switch to Bypass mode when the inverter failure or the UPS over-temperature. In Battery mode, the UPS will shut down and stop the output when the inverter failure or the UPS over-temperature. In Fault state, the fault indicators will turn on, the buzzer will keep beeping, and the corresponding fault information will be displayed on LCD panel.



In Fault state, if the bypass failure or bypass voltage is abnormal when the output is not overload, the UPS will shut down and be switched to the inverter for power supply, such as radiator over-hot. However, if the bypass failure or bypass voltage is abnormal when the output is overload, the UPS will not switch to the inverter for power supply, but shut down the bypass.

## 1.6 Specifications

The UPS specifications are listed in Table 1-2.

Table 1-2 UPS specifications

Product model		UHA3R-0160L	UHA3R-0200L
Input	Rated voltage	3-phase: 380Vac	
	Voltage range	304Vac ~ 478Vac, at full load 228Vac ~ 304Vac, linear derating 228Vac, at half load	
	Rated frequency	50Hz/60Hz	
	Frequency range	40Hz ~ 70Hz	
	Power factor	≥0.99, at full load; ≥0.98, at half load	
Output	Rated power	14.4kW	18kW
	Voltage	220Vac ± 1% (3-phase balance load)	
	Frequency sync range	Rated frequency ± 2Hz (range is settable: ±0.5Hz ~ ±3Hz)	
	Frequency track rate	1Hz/s. Range is settable: 0.1Hz/s ~ 3Hz/s (single), 0.2Hz/s (parallel)	
	Rated power factor	0.9	
	Crest factor	3:1	
	Voltage harmonic distortion	<2% (linear load), <5% (non-linear load)	
	Dynamic response recovery time	60ms	
	Overload capacity	105% ~ 125%, 5min 125% ~ 150%, 1min	
	Bypass voltage	Upper limit: +10%, +15% or +20%; default: +15% Lower limit: -10%, -20%, -30% or -40%; default: -20%	
Mains efficiency	>93%, up to 94%		
Battery	Type	Sealed, lead-acid, maintenance-free battery	
	Cell No.	30, 32, 34, 36, 38, 40	
	Rated voltage	360Vdc ~ 480Vdc	
	Charge power	4.5kW	
Transfer time	Mains ↔ Battery	0ms	
	Inverter ↔ Bypass	Synchronous transfer: ≤1ms Asynchronous transfer (default): ≤20ms Or 40ms, 60ms, 80ms and 100ms are available	
Noise		≤58dB	
Panel display mode		LED and LCD	
Safety		IEC/EN62040-1-1	
EMC	Conduction emission	IEC/EN62040-2	
	Immunity	I≤16A, IEC/EN61000-3-3; 16A<I≤75A, IEC/EN61000-3-11	
	Harmonic current	I≤16A, IEC/EN61000-3-2; 16A<I≤75A, IEC/EN61000-3-12; YD/T1095-2001, level 2, 15%	
Surge protection		IEC/EN-61000-4-5, endurance level 4 (4kV) (live line to earth), level 3 (2kV) (during live lines)	
Protection level		IP20	
Ambient condition	Operating temperature	0°C ~ +40°C	
	Storage temperature	-40°C ~ +70°C (battery excluded); -20°C ~ +55°C (battery included)	
	Relative humidity	5%RH ~ 95%RH, non-condensing	
	Altitude	<2000m; derating in accordance with GB/T3859.2 when higher than 2000m	
Size	W × H × D	435mm × 130mm × 750mm	
Weight	Net weight	35kg	
	Gross weight	38kg	

## Chapter 2 Installation

This chapter introduces the UPS installation. Each site has its peculiarities, so this chapter provides the guidance with general installation procedures and methods for the installing engineer, who should conduct the installation according to the actual conditions.



Warning: Professional Installation

The UPS equipment should be installed by a qualified engineer in accordance with the information contained in this chapter. If any problem is found, please get in touch with Emerson local service center immediately.  
Approved by the commissioning engineer, the UPS can be powered on.



Note: 3-phase 5-line for power supply input

The UPS can be connected to 3-phase 5-line (A, B, C, N, PE) TN, TT and IT AC power distribution system (IEC60364-3).



Warning: Battery Hazards

Special care should be taken into account when installing the battery. When connecting the battery, the voltage of the battery terminal will exceed 400Vdc hazardous voltage.

- Eyeshade should be worn to prevent injury from accidental electric arcs
- Remove rings, watches and all metal objects
- Use tools with insulated handles
- Wear rubber gloves
- If a battery leaks electrolyte, or is otherwise physically damaged, it must be replaced, stored in a container resistant to sulfuric acid and disposed of in accordance with local regulations
- If electrolyte comes into contact with the skin, the affected area should be washed immediately with water

### 2.1 Unpacking Inspection

After the UPS arrival, you should unpack the UPS and check the following items:

1. Visually inspect the UPS appearance for transportation damage. If any transportation damage is found, please notify the carrier immediately.
2. Check the accessories and models against the delivery list. If any discrepancy is found, please notify the dealer immediately.

### 2.2 Location

To extend the UPS life, the selection of the UPS location should be:

- Convenient wiring
- Adequate operator access area
- Well-ventilated location to meet heat rejection requirements
- Non-corrosive gas surrounded
- No excessive moisture and heat sources
- Free of dust
- Complied with fire-fighting requirements
- Temperature of operation environment complies with the specifications, see Table 1-2 for details

### 2.2.1 Distribution Room

The UPS is designed for indoor installation, which should be installed in clean and well-ventilated environment, so as to keep the ambient temperature within the specifications range.

The internal fans provide the forced air cooling for the UPS. Cooling air enters the UPS through the front ventilation holes, and exhausts the hot air through the back ventilation holes. Therefore, do not restrict the ventilation holes. The front, rear and side panels of the UPS should be kept at least 200mm distance from the wall or consecutive equipment, so as not to obstruct the UPS ventilation and heat rejection. Otherwise, the UPS internal temperature will rise, which will shorten the UPS life.

If necessary, an indoor extractor fan should be installed to keep the indoor temperature from rising. An air filter should be used where the UPS is to operate in a dirty environment.



Note

The UPS is only suitable for installing on the concrete surface or other non-flammable surface.

### 2.2.2 Battery Room

A small amount of hydrogen and oxygen will be produced at the end of battery charging, therefore, you must ensure the fresh air ventilation of battery installation environment to meet the EN50272-2001 requirements.

The battery ambient temperature should be the constant temperature, because the ambient temperature is the main factor to affect the battery capacity and life. The battery standard operating temperature is 20°C, operation above this temperature will shorten the battery life, and operation below this temperature will reduce the battery capacity. If the battery average temperature in run rises from 20°C to 30°C, the battery life will be reduced by 50%; if the battery temperature in run exceeds 40°C, the battery life will be decreased exponentially. In general, the enabled ambient temperature of the battery is 15°C ~ 25°C. The battery should be kept away from heat and ventilation holes.

When the UPS uses an external battery, you must install a battery protective device (such as fuse or circuit breaker), and the battery protective device should be installed in areas near the battery, and the battery connection between the alignment should be the shortest distance.

### 2.2.3 Storage

The UPS must be stored indoors to protect against excessive moisture or over-temperature environment, when the UPS does not need to be installed immediately. The battery requires dry and low temperature, well-ventilated environment for storage, and the most suitable storage temperature is 20°C ~ 25°C.



Warning: Battery Hazards

During the battery storage period, the battery must be periodically charged according to the battery instructions. You can connect the UPS to the mains temporarily when charging the battery, so as to activate the battery for battery charge.

## 2.3 Installation tools

Prepare installation tools according to Table 2-1. The tools must be insulated and ESD-proof processed prior to use.

Table 2-1 Installation tools list

Installation tool	Specification	Application
Cross screwdriver	EJ5100mm	Remove the protective cover of terminal block, connect power cables
Wire-pressure plier	YT-12	Press wires for terminal block
Diagonal plier	MTC3C	Make cables

## 2.4 Mechanical Installation



Note

The UPS is suitable for resistive-capacitive load (like computer), resistive load and micro-inductive load. It is not suitable for purely inductive load or purely capacitive load (like motor, air-conditioner and duplicator), nor can it be connected to half-wave rectifier load.

Two installation modes are available: tower installation and rack installation. You can select an appropriate installation mode according to the actual conditions.

According to the different configuration requirements, the UPS has two configurations: battery modules excluded, and four battery modules. For tower installation, you should prepare the battery rack and battery cabinet for installing the battery modules; for rack installation, the battery modules and the UPS can be installed in the same rack together.

### 2.4.1 Tower Installation

1. Assemble a pair of support bases (accessories) and a support base extension (accessory) together through fastenings, as shown in Figure 2-1.

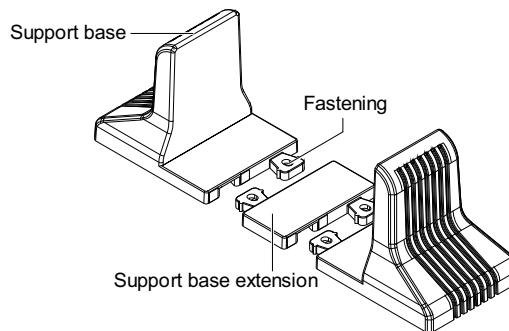

Figure 2-1 Connecting the support base with support base extension

2. Repeat step 1 to connect another pair of support bases with a support base extension.  
3. Place the UPS on the support bases and support base extensions, as shown in Figure 2-2.

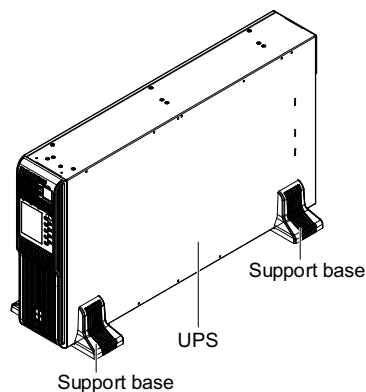

Figure 2-2 Installation complete



Note

For tower installation, two pairs of support bases should be placed respectively at both sides of the UPS, as shown in Figure 2-2. Otherwise, the UPS may be dumped.

## 2.4.2 Rack Installation

### Installation procedures for battery modules excluded

1. Take out eight M4\*10 screws, and fix two brackets (accessories) respectively on both sides of the UPS front panel, as shown in Figure 2-3.

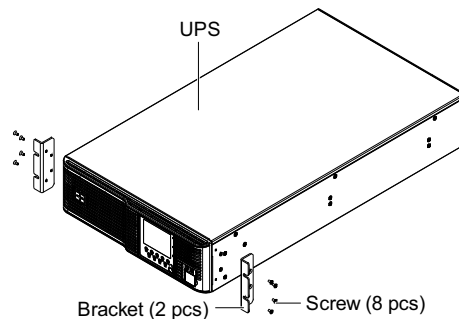

Figure 2-3 Installing brackets



Note

Moving the UPS through brackets is prohibited.

2. Place the UPS onto the guide rails in the rack, and push it completely into the rack. Take out four M6\*16 screws to fix the UPS on the rack through brackets, as shown in Figure 2-4.

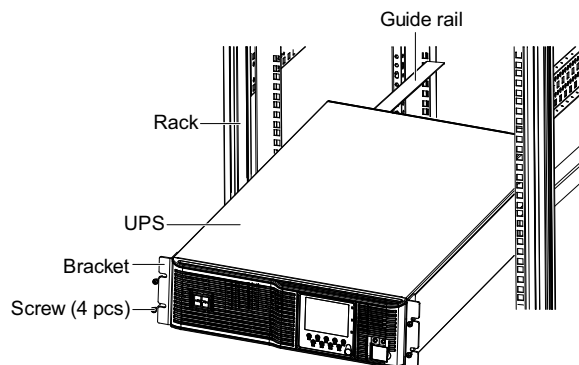

Figure 2-4 Installing the UPS

### Installation procedures for battery modules included

The installation method of the battery module is the same as that of the UPS. Repeat the above procedures to install and fix the four battery modules and UPS on the rack one by one. As the battery module is heavy, you should pay attention to the following items in installation:

- Two persons or more are required for the installation
- First install the battery module, then start the installation from the bottom, and place the UPS onto the top, as shown in Figure 2-5
- Moving the UPS and battery modules through brackets is prohibited

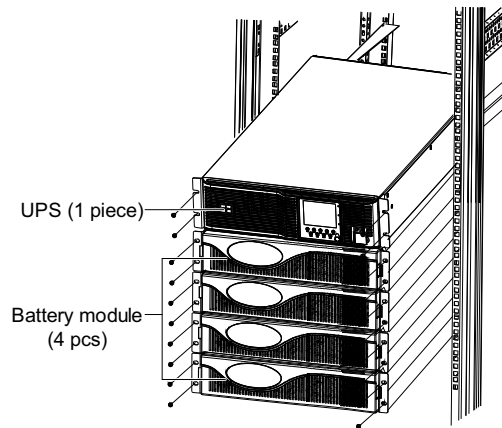

Figure 2-5 UPS installation diagram of battery modules included

## 2.5 External Protective Device

The circuit breaker or other protective devices must be installed at the external AC input port of the UPS. This section provides general guidance for the qualified installing engineers. The qualified installing engineers should learn about the related knowledge about the local wiring regulations for the equipment to be installed.

### 2.5.1 Rectifier And Bypass Inputting

#### Overcurrent

The appropriate overcurrent protective device should be installed on the mains input distribution, and you should take the current capacity of power cable as well as the system overload requirements into account in installation (see Table 1-2). It is generally recommended to use the thermomagnet circuit breaker of IEC60947-2 tripping curve C (normal), following the 125% of current value listed in Table 2-2.

Bypass disconnection: When the system uses bypass disconnection, the protective devices should be respectively installed at the mains input distribution for main input and bypass input.

#### Main/Bypass reflected protection

When using the main/bypass reflected protection function, the gross mains input needs to be equipped with the protective devices with auxiliary contact function. The recommended model: S1N125 R125 TM FFC 4P + 1A + 1B + YO (220Vac).



Note

The same neutral line must be used for the rectifier and bypass input power.  
For IT power grid system, the protective device with four poles must be installed at the UPS external I/O distribution.

#### Earth leakage current

The residual current detector device (RCD) for the UPS upstream input distribution should:

- Be sensitive to the DC unidirectional pulse (level A) in distribution network
- Be insensitive to the transient current pulse
- Be the general sensitivity type, settable: 0.3A ~ 1A

The residual current circuit breaker (RCCB) must be sensitive to the DC unidirectional pulse (level A) in distribution network, and insensitive to the transient current pulse, as shown in Figure 2-6 respectively.

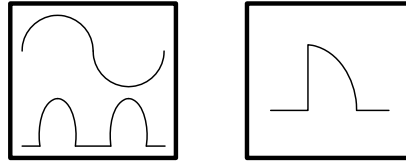

Figure 2-6 RCCB symbols

When using the earth leakage current test device in bypass disconnection system or parallel system, the RCD should be located at the upstream input distribution terminal to avoid generating the false alarm.

The earth leakage current introduced by the RFI filter in the UPS ranges from 3.5mA to 1000mA. It is recommended to confirm the sensitivity of each differential device of the upstream input distribution and downstream distribution (to load).

### 2.5.2 Battery Input

The over-current protective device has been placed into the battery module, when you choose the battery module options provided by Emerson. Otherwise, the external battery cabinet should provide DC compatible circuit breaker, so as to provide the over-current protection for the UPS and its batteries.

### 2.5.3 UPS Output

The protective device must be installed for the UPS output distribution. The protective device must be different from the input distribution protection switches, and it also provides the overload protection (see Table 1-2).

## 2.6 Connecting Power Cables

I/O cables and battery cables are needed to be connected. Battery modules provide the battery cable options.

When designing the cables, you should follow the instructions in this section and the local wiring regulations, take the environment situation into account, and refer to Table 3B of IEC60950-1.

 Warning	
1. Before carrying out the UPS wiring, ensure that you have learned about the location and status of the UPS input and mains distribution switch. Make sure that the switches are in open state, and put up the warning mark to prevent the switches from operating by others.	
2. Failure to follow adequate earthing procedures can result in electromagnetic interference, electric shock hazard to personnel, or the risk of fire.	

### 2.6.1 Cables Selection

Select the cables according to Table 2-2.

Table 2-2 Maximum steady state AC and DC current

UPS rated power (kVA)	Rated current (A)						Battery discharging current upon Min battery voltage
	Mains input current <sup>1, 2</sup> when battery charging with Max ability			Gross output current <sup>2</sup> at full load			
	380V	400V	415V	380V	400V	415V	
16 (3-in 3-out)	33	33	33	24	23	22	54
16 (3-in 1-out)	33	33	33	72	70	67	54
20 (3-in 3-out)	36	36	36	30	29	28	67
20 (3-in 1-out)	36	36	36	90	87	84	67

Note:

- The mains input current of the rectifier and bypass.
- Non-linear load (switch mode power supply) affects the neutral cable design of output and bypass. The neutral cable current may exceed the rated phase current, in general, 1.732 times the rated current

1. PE line: Use the shortest wiring route when connecting the cabinet earth cable. The cross-sectional area (CSA) of the earth cable should be selected according to the AC power fault level, cable length and protection type. According to AS/IEC60950-1, the CSA is 10mm<sup>2</sup> (20kVA, 3-in 3-out), 25mm<sup>2</sup> (20kVA, 3-in 1-out) as usual.
2. When selecting the battery cables, according to the current value shown in Table 2-2, the Max allowable voltage drop is 4Vdc. Do not ring the cables, which can avoid increasing the EMI.

## 2.6.2 Connecting I/O Cables

### Distribution mode and terminal block

#### 1. Distribution mode

There are two modes for UPS distribution: single power output distribution unit (POD) options provided by Emerson, external distribution by the user.

According to the actual requirements, the I/O cable connections are divided into the following four types: 3-in 3-out, common source configuration (factory default), 3-in 3-out, split-bypass configuration, 3-in 1-out, common source configuration, 3-in 1-out, split-bypass configuration. In accordance with the four types of the two distribution methods, this section will introduce the I/O cables connection procedures respectively.



Note

This product is compatible with 3-in 3-out/3-in 1-out, default: 3-in 3-out. Change format according to the following steps, if you need the 3-in 1-out system:

1. After the 3-in 1-out I/O connections are finished by following the instructions in this section, power on the system, then press the emergency power-off (EPO) switch immediately.
2. Set the system to 'Single Phase Output' through the LCD menu 'Settings' -> '3-in 3-out/3-in 1-out'.
3. Power off the system completely, then power on again, the system will run in 3-in 1-out mode.

#### 2. Terminal block

The power cables connection of the UPS should be connected through the I/O terminal block located on the UPS rear panel. Figure 2-7 gives the terminals distribution of the I/O terminal block.

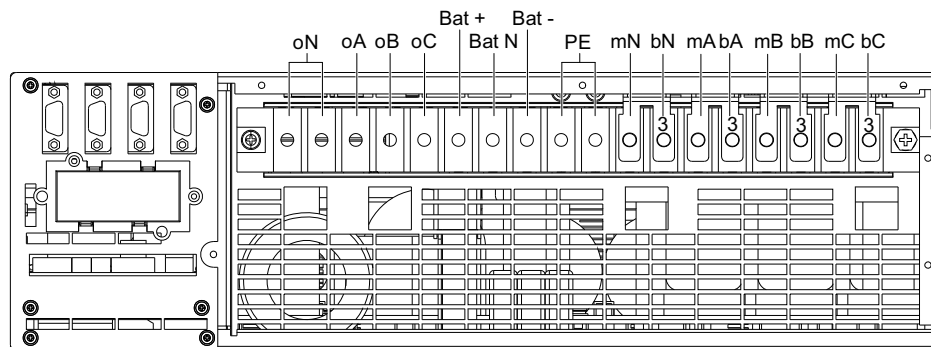

- Note: 1. Main input: mA, mB, mC, mN; Bypass input: bA, bB, bC, bN  
Output: oA, oB, oC, oN; Battery: Bat +, Bat N, Bat -; GND: PE  
2. In factory, four shorted copper bars 3 have been used to short terminals between mA and bA, mB and bB, mC and bC, mN and bN respectively

Figure 2-7 Terminals distribution of the I/O terminal block

When using the single POD options, the UPS power cables should be connected through the user terminal block of the single POD rear panel, UPS terminal block and PE terminals. The terminal distribution of each terminal block on the POD rear panel and the PE terminals are shown in Figure 2-8.

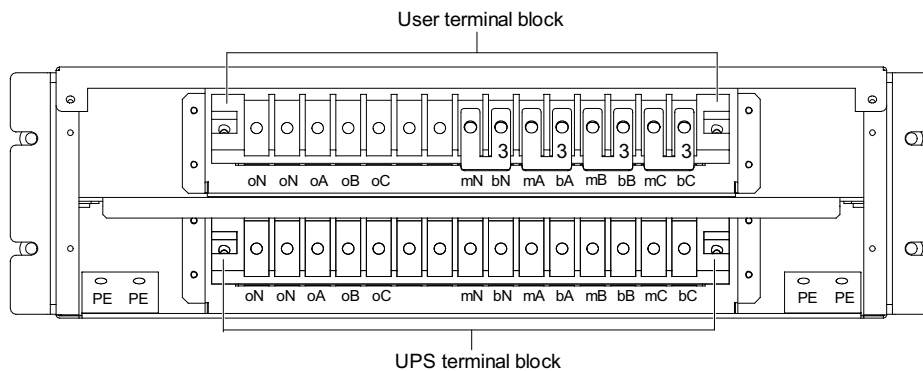

- Note: 1. Main input: mA, mB, mC, mN; Bypass input: bA, bB, bC, bN  
Output: oA, oB, oC, oN; Battery: Bat +, Bat N, Bat -; GND: PE  
2. In factory, four shorted copper bars 3 have been used to short terminals between mA and bA, mB and bB, mC and bC, mN and bN respectively

Figure 2-8 Terminals distribution of the terminal block and PE terminals

The UPS I/O terminal block, the single POD user terminal block and the UPS terminal block all have protective cover. Before the connection, you should remove the protective cover of each terminal block; after the connection, you should reinstall the protective cover.

	Warning
<p>After the cables connection, you must reinstall the protective cover for each terminal block, so as to avoid the electric shock when the UPS is in operation.</p>	

#### Using the single POD options (Recommended)

- 3-in 3-out, common source configuration (factory default)

1. Connect the live line (input phase A, phase B and phase C), N line and PE line respectively to the user terminal block (terminal mA, mB, mC and mN) of the single POD, and PE terminals.
2. Connect the live line (output phase A, phase B and phase C), N line and PE line respectively to the user terminal block (terminal oA, oB, oC and oN) of the single POD, and PE terminals.
3. Remove all the shorted copper bars 3 from the UPS I/O terminal block, connect the UPS terminal block of the single POD with the same silk screen terminal of the UPS I/O terminal block using the one-to-one correspondence method, and connect the two PE terminals of the UPS I/O terminal block to the single POD terminals.

- 3-in 3-out, split-bypass configuration

1. Remove all the shorted copper bars 3 from the single POD user terminal block.
2. Connect the live line (main input phase A, phase B and phase C), N line and PE line respectively to the user terminal block (terminal mA, mB, mC and mN) of the single POD, and PE terminals.
3. Connect the live line (bypass input phase A, phase B and phase C), N line and PE line respectively to the user terminal block (terminal bA, bB, bC and bN) of the single POD.
4. Connect the live line (output phase A, phase B and phase C) and N line respectively to the user terminal block (terminal oA, oB, oC and oN) of the single POD user terminal block.
5. Remove all the shorted copper bars 3 from the UPS I/O terminal block, connect the UPS terminal block of the single POD with the same silk screen terminal of the UPS I/O terminal block using the one-to-one correspondence method, and connect the two PE terminals of the UPS I/O terminal block to the single POD terminals.

- 3-in 1-out, common source configuration

 Note
Except for the shorted copper bar 3, all the shorted copper bars mentioned in the installation procedures are the delivery accessories.

1. Short the terminal bA, bB and bC of the single POD user terminal block using the shorted copper bar 7, short the terminal oA, oB and oC using the shorted copper bar 5, and short mA and bA terminals using the shorted copper bar 6 and then short mN and bN terminals, two oN terminals respectively using two shorted copper bars 4, as shown in Figure 2-9.

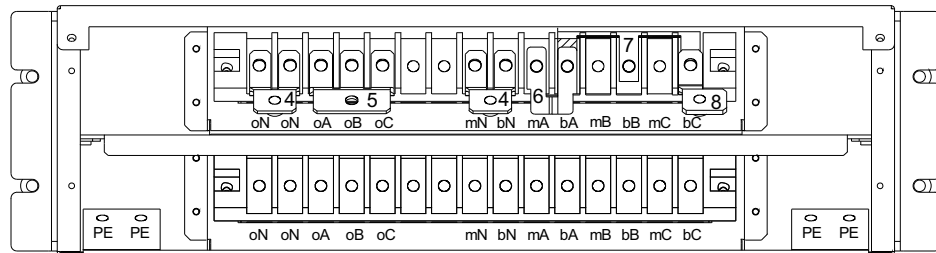

Figure 2-9 Shorted copper bar connection for the single POD user terminal block

2. Connect the shorted copper bar 8 to one end of the shorted copper bar 7 (see Figure 2-9), and connect the live line (input phase A) to the shorted copper bar 8.
3. Connect the live line (input phase B, phase C), N line and PE line respectively to mB and mC terminals of the single POD user terminal block, shorted copper bars 4 of mN and bN terminals, and PE terminals.
4. Connect the live line (output phase A), N line and PE line respectively to the shorted copper bar 5 of the single POD user terminal block, shorted copper bars 4 of the two oN terminals, and PE terminals.
5. Remove all the shorted copper bars 3 from the UPS I/O terminal block, and connect the UPS terminal block of the single POD with the same silk screen terminal of the UPS I/O terminal block using the one-to-one correspondence method.
6. As shown in Figure 2-10, you can paste the insulating film (accessory) to the shorted copper bar 10, and insert the buckles into the corresponding holes on the shorted copper bar 10.

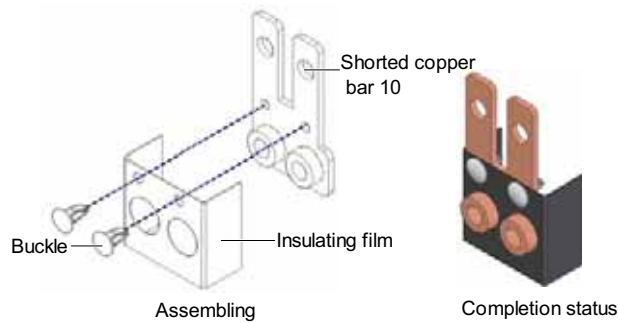

Figure 2-10 Pasting insulating film to shorted copper bar 10

7. As shown in Figure 2-11, you can short two PE terminals of the UPS I/O terminal block using the shorted copper bar 10 with insulating film, and connect two screw holes of the shorted copper bar 10 to the PE terminals of the single POD.

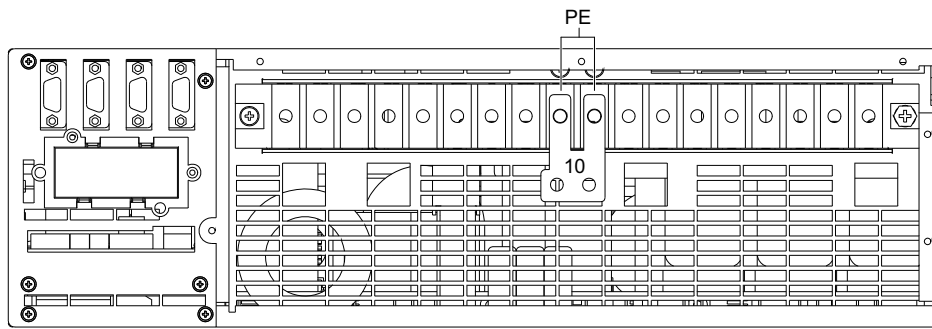

Figure 2-11 Shorted copper bar 10 for PE terminals of the UPS I/O terminal block

● 3-in 1-out, split-bypass configuration

1. Short the terminal bA, bB and bC of the single POD user terminal block using the shorted copper bar 7, short the terminal oA, oB and oC using the shorted copper bar 5, and then short mN and bN terminals, two oN terminals respectively using two shorted copper bars 4, as shown in Figure 2-12.

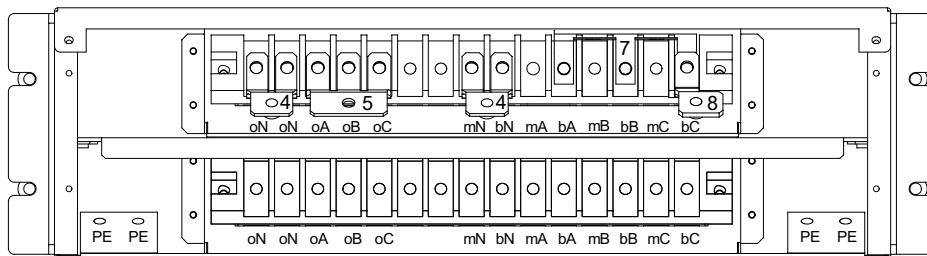

Figure 2-12 Shorted copper bar connection for the single POD user terminal block

2. Connect the live line (main input phase A, phase B, phase C), N line and PE line respectively to terminal mA, mB and mC of the single POD user terminal block, shorted copper bars 4 of mN and bN terminals, and PE terminals.
3. Connect the shorted copper bar 8 to one end of the shorted copper bar 7 (see Figure 2-12), and connect the live line (bypass input phase A) to the shorted copper bar 8.
4. Connect the bypass input N line to terminal mN of the single POD user terminal block, and the shorted copper bar 4 of bN.
5. Connect the live line (output phase A), N line and PE line respectively to the shorted copper bar 5 of the single POD user terminal block, shorted copper bars 4 of the two oN terminals, and PE terminals.
6. Remove all the shorted copper bars 3 from the UPS I/O terminal block, and connect the UPS terminal block of the single POD with the same silk screen terminal of the UPS I/O terminal block using the one-to-one correspondence method.
7. As shown in Figure 2-10, you can paste the insulating film (accessory) to the shorted copper bar 10, and insert the buckles into the corresponding holes on the shorted copper bar 10.
8. As shown in Figure 2-11, you can short two PE terminals of the UPS I/O terminal block using the shorted copper bar 10 with insulating film, and connect two screw holes of the shorted copper bar 10 to the PE terminals of the single POD.

**Self-distribution**

Before carrying out the self-distribution, the protective devices such as the main input MCB, bypass input MCB, output MCB and maintenance MCB should be prepared by the user. It is recommended to use the 63A main input MCB, 125A bypass input MCB, and 100A output MCB.

● 3-in 3-out, common source configuration (default)

1. Connect the live line (input phase A, phase B and phase C), N line and PE line respectively to terminal mA, mB, mC and mN of the UPS I/O terminal block, and PE terminals.
2. Connect the live line (output phase A, phase B, and phase C), N line and PE line respectively to terminal oA, oB, oC and oN of the UPS I/O terminal block, and PE terminals.

● 3-in 3-out, split-bypass configuration

1. Remove all the shorted copper bars 3 from the UPS I/O terminal block.
2. Connect the live line (main input phase A, phase B and phase C), N line and PE line respectively to terminal mA, mB, mC and mN of the UPS I/O terminal block, and PE terminals.
3. Connect the live line (bypass input phase A, phase B and phase C), N line and PE line respectively to terminal bA, bB, bC and bN of the UPS I/O terminal block.
4. Connect the live line (output phase A, phase B and phase C), N line and PE line respectively to terminal oA, oB, oC and oN of the UPS I/O terminal block, and PE terminals.

● 3-in 1-out, common source configuration

1. As shown in Figure 2-10, you can paste the insulating film (accessory) to the shorted copper bar 10, and insert the buckles into the corresponding holes on the shorted copper bar 10.
2. As shown in Figure 2-13, you can short two PE terminals of the UPS I/O terminal block using the shorted copper bar 10 with insulating film, short the terminal bA, bB and bC using the shorted copper bar 7, short the terminal oA, oB and oC using the shorted copper bar 5, and short mA and bA terminals using the shorted copper bar 6 and then short mN and bN terminals, and two oN terminals using two shorted copper bars 4.

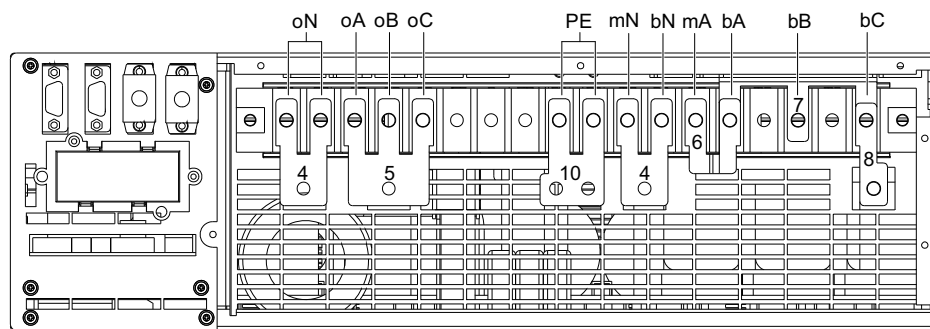

Figure 2-13 Shorted copper bar connection for the UPS I/O terminal block

2. Connect the shorted copper bar 8 to one end of the shorted copper bar 7 (see Figure 2-13), and connect the live line (input phase A) to the shorted copper bar 8.
3. Connect the live line (input phase B, phase C), N line, PE line respectively to mB and mC terminals of the UPS I/O terminal block, shorted copper bars 4 of mN and bN terminals, and one screw hole of the shorted copper bar 10.
4. Connect the live line (output phase A), N line and PE line respectively to the shorted copper bar 5 of the UPS I/O terminal block, shorted copper bars 4 of the two oN terminals, and the other screw hole of the shorted copper bar 10.

● 3-in 1-out, split-bypass configuration

1. As shown in Figure 2-10, you can paste the insulating film (accessory) to the shorted copper bar 10, and insert the buckles into the corresponding holes on the shorted copper bar 10.
2. Short two PE terminals of the UPS I/O terminal block using the shorted copper bar 10 with insulating film, short the terminal bA, bB and bC using the shorted copper bar 7, and short the terminal oA, oB and oC using the shorted copper bar 5, and then short mN and bN terminals and two oN terminals using two shorted copper bars 4, as shown in Figure 2-14.

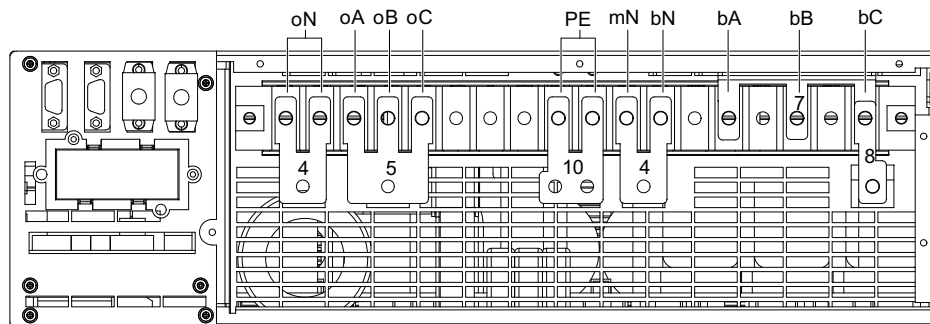

Figure 2-14 Shorted copper bar connection for the UPS I/O terminal block

3. Connect the live line (main input phase A, phase B and phase C), N line, PE line respectively to the terminal mA, mB and mC of the UPS I/O terminal block, shorted copper bars 4 of mN and bN terminals, and one screw hole of the shorted copper bar 10.
4. Connect the shorted copper bar 8 to one end of the shorted copper bar 7 (see Figure 2-14), and connect the live line (bypass input phase A) to the shorted copper bar 8.
5. Connect the bypass input N line to mN of the UPS I/O terminal block, and the shorted copper bar 4 of bN.
6. Connect the live line (output phase A), N line and PE line respectively to the shorted copper bar 5 of the UPS I/O terminal block, shorted copper bars 4 of the two oN terminals, and the other screw hole of the shorted copper bar 10.



Note

Before the commissioning engineer arrival, if the load is not ready for accepting the power supply, please take good care of the safety insulation located at the end of the output cable.

After the I/O cables connection, you should find the label shown in Figure 2-15 on the UPS chassis protective cover for convenient maintenance, and then tick '√' at the right side of the 'AC OUTPUT' and 'BYPASS INPUT', according to the actual conditions.

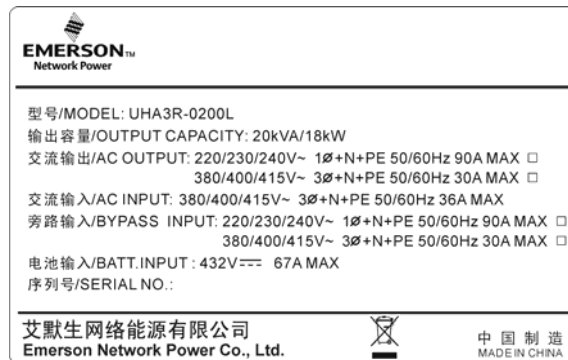

Figure 2-15 Label

### 2.6.3 Connecting Battery Cables



Note

If battery module is not selected, this product needs to be equipped with positive and negative batteries. Each group ranges from 15-cell to 20-cell, and 12V for each cell.

Connection procedures for battery cables are as follows:

1. Confirm that all UPS external I/O switches are open.
2. Connect the battery cables.
  - Selected battery modules (4 pcs)
    - 1) Take out a battery cable option from the battery module, insert the battery cable which marked with 'Battery Module 1', 'Battery Module 2', 'Battery Module 3' and 'Battery Module 4' respectively into any battery port on the rear panel of the four battery modules (see Figure 2).
    - 2) Ground one end of the battery cable which marked with 'UPS PE'.
    - 3) Connect the other end of the battery cable which marked with 'BAT +', 'BAT N', 'BAT -' respectively to the terminal 'Bat +', 'Bat N', 'Bat -' of the UPS I/O terminal block (see Figure 2-7).
    - 4) Tighten the fixing screws on both battery port sides of the battery module through screwdriver, so as to prevent the battery cable from loosening or coming off.
  - Non-selected battery modules

Connect the external battery with terminal '+', 'N' and '-' respectively to the terminal 'Bat +', 'Bat N', 'Bat -' of the UPS I/O terminal block (see Figure 2-7).



Note

1. It is prohibited to reverse the positive pole and negative pole of the battery.
2. Before replacing the battery module and connecting the battery cables, ensure that the UPS system is in maintenance mode.
3. The length of the battery cable option is 1.5m. If you need more length cables, please consult the dealer. It is recommended that the battery cable be shorter than 3m. Otherwise, the UPS cannot operate normally.

## 2.7 Connecting Communication Cables

Communication cables include: dry contact communication cable, USB communication cable and SNMP card communication cable.

All the communication cables are the dual insulation cables which must be separated from the power cables for wiring. When the longest connection distance ranges from 25m to 50m, the CSA should be ranged from 0.5mm<sup>2</sup> to 1.5mm<sup>2</sup>.

### 2.7.1 Connecting Dry Contact Communication Cable

The UPS provides five dry contact ports, see Figure 1-2 for specific positions. The silk screens of the five dry contact ports are 1, 2, 3, 4, 5. The pin distribution for each dry contact port is shown in Figure 2-16, and the port description is shown in Table 2-3.

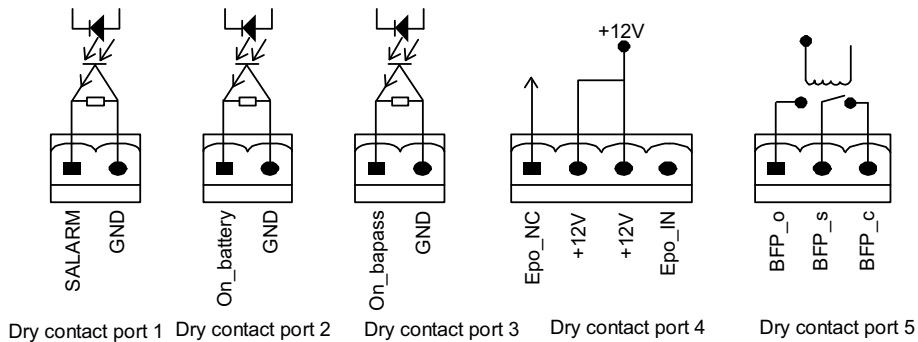

Figure 2-16 Pin distribution of dry contact ports

Table 2-3 Description of the dry contact ports

Silk screen	Port name	Pin NO.	Pin name	Meaning
1	Output port of alarm	1.1	S_ALARM	The signal level is 12V, when the system alarms
		1.2	GND	GND
2	Output port of battery status	2.1	ON_BATTERY	The signal level is 12V, when the system runs in battery inversion mode
		2.2	GND	GND
3	Output port of bypass status	3.1	ON_BYPASS	The level is 12V, when the system runs in bypass mode
		3.2	GND	GND
4	Input port of remote EPO *	4.1	EPO_NC	EPO activated, when opened to 4.2
		4.2	+12V	EPO activated, when opened to 4.1
		4.3	+12V	EPO activated, when shorted to 4.4
		4.4	EPO_IN	EPO activated, when shorted to 4.3
5	Output port of bypass reflected	5.1	BFP_O	Bypass reflected protection relay (normally open), the bypass SCR will close when short circuit appears
		5.2	BFP_S	The middle point of the bypass reflected protection relay
		5.3	BFP_C	Bypass reflected protection relay (normally open), the bypass SCR will open when short circuit appears

Note\*: Pin1 and pin2, or pin3 and pin4 of the dry contact port 4 reserves the corresponding terminals for configuring the EPO function. The external EPO device also needs the shielded cable to connect to the normally open/close remote EPO switch between the two terminals. If not necessary, you should disconnect pin3 and pin4 of the dry contact port 4, or short pin1 and pin2 of the dry contact port 4. Pin1 and pin2 of the dry contact port 4 have been shorted before delivery



Note

The EPO action of the UPS will close the rectifier, inverter and static bypass, but it can not disconnect the UPS mains input inside. If you want to disconnect the UPS completely, just disconnect the upstream input switch before generating the EPO,.

## 2.7.2 Connecting USB Communication Cable

Insert one end of the USB communication cable accessory into the USB port on the UPS rear panel (see Figure 1-2), and insert the other end of the USB communication cable into the USB port of the computer.

## 2.7.3 Connecting SNMP Card Communication Cable

The UPS provides the installation communication components of the SNMP card port (see Figure1-2), including: SNMP card, dry contact card and MODBUS card. For the installation and usage of the communication components, refer to the delivered documentation for each communication component. SNMP card port and USB port can be used together.

The pin distribution for each SNMP card port is shown in Figure 2-17.

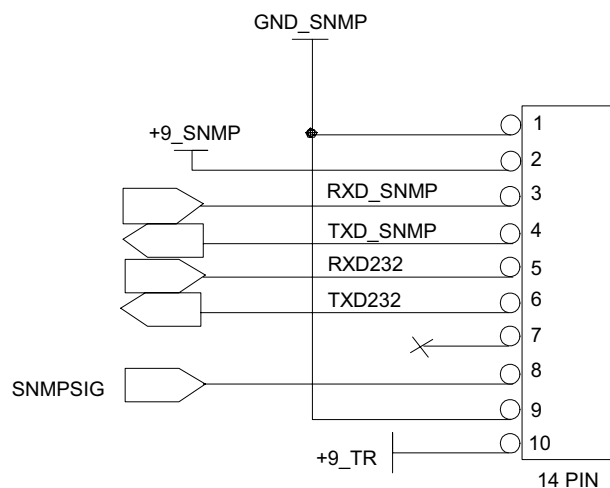

Figure 2-17 Pin distribution of SNMP card ports

The pin description for each SNMP card port is shown in Table 2-4.

Table 2-4 Pin description of the SNMP card ports

Pin	Description
1, 9	GND of SNMP card
2	SNMP card power supply provided by DSP panel
3	Signal from the SNMP card, which connects with RXD of the DSP
4	Signal to SNMP card, which connects with TXD of the DSP
5	Connect with RX of the RS232 communication port of the host
6	Connect with TX of the RS232 communication port of the host
7	Reserved
8	Selected communication signal, +9_TR is introduced into this pin after the SNMP card is plugged
10	The power supplied by DSP panel, for selecting the card



Note

If you wish to connect the SNMP card (model: UF-SNMP810) to Emerson temperature sensor (model: RDU-A-S01T) to make it be the battery temperature compensation, please connect the COM1 port of the SNMP card, and set the temperature sensor DIP address to '1'.



Warning

The DIP switch on the UPS front panel (see Figure1-1) is used to set the parallel address for each UPS single in parallel system installation. You are not required for setting the DIP switch in UPS single system installation. Set the DIP switch at will can result in UPS fault!

## 2.8 Parallel System

The UPS parallel system provides the user with  $N + X$  ( $2 \leq N + X \leq 4$ ) parallel configuration,  $N$  stands for the basic parallel sets,  $X$  stands for the redundant sets.

The UPS parallel system has 1 + 1 parallel POD options, which provide safe and reliable distribution function for parallel system. The 1 + 1 parallel system only needs one 1 + 1 parallel POD; if  $N \geq 2$ , the self-distribution will be required for the parallel system.

Installing parallel system includes:

- Mechanical installation
- Setting parallel addresses
- Connecting parallel cables
- Connecting 1 + 1 parallel POD cables

### 2.8.1 Mechanical Installation

Taking the rack installation of the 1 + 1 parallel system with battery module for example, the mechanical installation method of the parallel system is as follows:

1. The installation method of 1 + 1 parallel POD is the same as that of the UPS. Refer to 2.4.2 *Rack Installation for details*.
2. As shown in Figure 2-18, the battery module should be installed at the bottom, the UPS should be installed in the middle, and the 1 + 1 parallel POD should be installed on the top, so as to facilitate the cable connection and operation.

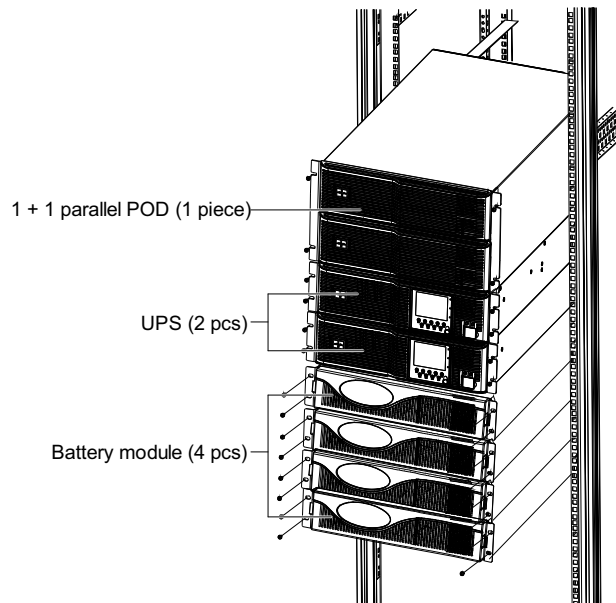

Figure 2-18 1 + 1 parallel system with battery modules

## 2.8.2 Setting Parallel Addresses

The parallel addresses for all the UPS singles in parallel system should be set. The parallel addresses can be set through the DIP switch on the UPS front panel (see Figure 1-1). Remove the DIP switch protective cover, and set the DIP switch according to Table 2-5. The parallel address must be unique for each UPS single.

Table 2-5 DIP switch settings

Parallel addresses	Parallel 1#	Parallel 2#	Parallel 3#	Parallel 4#
DIP switch position	<p>ON <input checked="" type="checkbox"/> <input type="checkbox"/> <input type="checkbox"/> <input type="checkbox"/> <input type="checkbox"/>  <input type="checkbox"/> <input checked="" type="checkbox"/> <input checked="" type="checkbox"/> <input checked="" type="checkbox"/> <input checked="" type="checkbox"/>  DIP1 DIP2 DIP3 DIP4 DIP5</p>	<p>ON <input type="checkbox"/> <input checked="" type="checkbox"/> <input type="checkbox"/> <input type="checkbox"/> <input type="checkbox"/>  <input checked="" type="checkbox"/> <input type="checkbox"/> <input checked="" type="checkbox"/> <input checked="" type="checkbox"/> <input checked="" type="checkbox"/>  DIP1 DIP2 DIP3 DIP4 DIP5</p>	<p>ON <input checked="" type="checkbox"/> <input checked="" type="checkbox"/> <input type="checkbox"/> <input type="checkbox"/> <input type="checkbox"/>  <input type="checkbox"/> <input type="checkbox"/> <input checked="" type="checkbox"/> <input checked="" type="checkbox"/> <input checked="" type="checkbox"/>  DIP1 DIP2 DIP3 DIP4 DIP5</p>	<p>ON <input type="checkbox"/> <input type="checkbox"/> <input checked="" type="checkbox"/> <input type="checkbox"/> <input type="checkbox"/>  <input checked="" type="checkbox"/> <input checked="" type="checkbox"/> <input type="checkbox"/> <input checked="" type="checkbox"/> <input checked="" type="checkbox"/>  DIP1 DIP2 DIP3 DIP4 DIP5</p>



Warning

The default setting for DIP switch is '1', you can set the DIP switch to 2, 3 or 4. However, you should set the DIP switch position according to the descriptions listed in Table 2-5. Otherwise, the UPS fault will be caused!

## 2.8.3 Connecting Parallel Cables

The parallel system provides the parallel cable options. Through the parallel ports (see Figure 1-2) on the UPS rear panel, the parallel cables are connected in close-loop mode one by one. Taking the 3 + 1 parallel system for example, the schematic diagram of the parallel cables connection is shown in Figure 2-19.

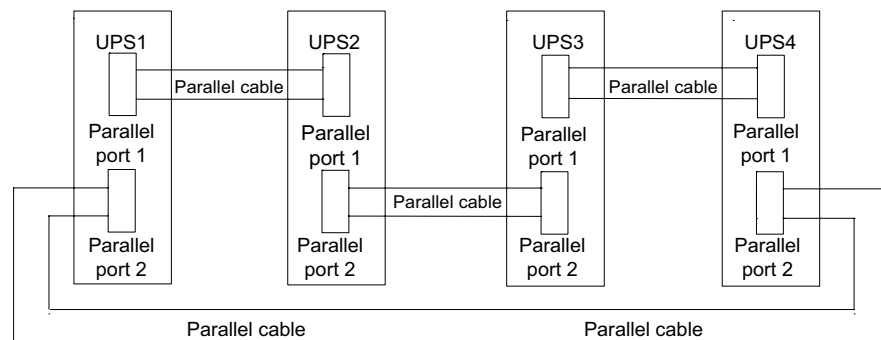

Figure 2-19 Parallel cables connection schematic diagram (3 + 1 parallel system)

## 2.8.4 Connecting 1 + 1 Parallel POD Cables

Connecting 1 + 1 parallel POD cables includes: connecting cables between the UPS and 1 + 1 parallel POD and connecting input and output cables of the 1 + 1 parallel POD.

### Connecting cables between the UPS and 1 + 1 parallel POD

Connect the UPS1 terminal block (silk screen: UPS1) on the 1 + 1 parallel POD rear panel to the same silk screen terminal on the UPS1 # rear panel I/O terminal block using the one-to-one correspondence method. Connect the UPS2 terminal block (silk screen: UPS2) on the 1 + 1 parallel POD rear panel to the same silk screen terminal on the UPS2 # rear panel I/O terminal block using the one-to-one correspondence method.



Note

1. When connecting cables, connect the UPS end at first, and then connect the 1 + 1 parallel POD end.
2. For kinds of system connection differences such as 3-in 3-out (common source configuration), 3-in 3-out (split-bypass configuration), 3-in 1-out (common source configuration), 3-in 1-out (split-bypass configuration), refer to 2.6.2 *Connecting The I/O Cables*.

### Connecting I/O cables of the 1 + 1 parallel POD



Note

1. A protective MCB must be series connected between the 1 + 1 parallel POD and the mains. It is recommended to use 80A MCB in main input and 150A MCB in bypass input.
2. Confirm reliable connection for the earth cable.

1. Connect the input cables.

- For 3-in 3-out parallel system, connect the input cables (U, V, W, N, PE) respectively to the corresponding terminals on the user terminal block (silk screen: USER) of the 1 + 1 POD rear panel.
- For 3-in 1-out parallel system, connect the input cables (L, N, PE) respectively to the corresponding terminals on the user terminal block of the 1 + 1 POD rear panel.

2. Connect the output cables.

Connect one end of the output cable to the user terminal block of the 1 + 1 parallel POD, and connect the other end of the output cable to the load.

## 2.9 Common Battery Strings

All the UPS singles in parallel system not only can share the battery strings, but also can use the battery strings independently. The battery strings sharing in parallel system can save money for you.

The following section will introduce the connection and setting operation of common battery strings in parallel system.



Note

Each UPS single should be equipped with the independent battery MCB. Refer to Table 2-2 and voltage of battery strings for battery MCB type.

1. Connection: Power off the system completely and disconnect all the battery MCBs of the UPS single, and then connect the terminal '+', 'N' and '-' of the shared battery strings respectively to the terminal 'Bat +', 'Bat N' and 'Bat -' (see Figure 2-7) of the corresponding UPS single I/O terminal block in parallel system, through each battery MCB.
2. Setting: Power on the system, set each UPS single to battery strings sharing configuration through the LCD menu 'Function Settings' -> 'Common Battery Strings Settings' from each UPS single; set the LCD menu 'Function Settings' -> 'Battery Cell Settings' and 'Battery Capacity Settings' from each UPS single, and each single setting must be the same.



Note

When the parallel system uses the battery strings sharing, the 'Battery Capacity' of the LCD settings of each UPS single stands for the gross capacity of battery strings, and each single can calculate the battery capacity itself automatically.

3. Close the battery MCB for each single.

## 2.10 Double Bus System

### 2.10.1 System Installation

The double bus system is composed of two independent UPS system, and each UPS system can be composed of one or two parallel UPS singles. The double bus system has high reliability, which is suitable for the load with many input terminals. For single input load, you can add a selected static trigger switch (STS) to start the load bus synchronization (LBS).

The double bus system uses LBS to realize the output sync of the two independent (or parallel) UPS systems. One is the main system, and the other is the slave system. The operation mode of the double bus system contains main

system and/or slave system for running in Normal or Bypass mode. The typical double bus system is shown in Figure 2-20.

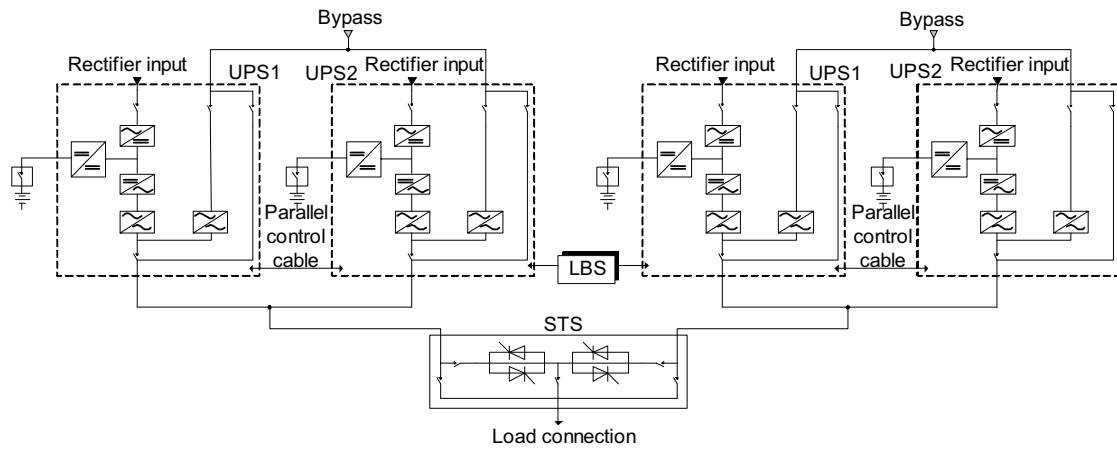

Figure 2-20 Typical double bus system (with the STS and LBS)

### 2.10.2 External Protective Device

See 2.5 External Protective Device.

### 2.10.3 Power Cables

See 2.6 Connecting Power Cables.

### 2.10.4 LBS Control Cables

Just connect the LBS cables respectively to any two LBS ports (see Figure 1-2) of the two parallel systems.

## Chapter 3 Operation And Display Panel

This chapter introduces the functions and use of the components on the UPS operation and display panel, and provides LCD display information, including the LCD screen types, detailed menu messages, prompt windows and UPS alarm message list.

### 3.1 Introduction

The operation and display panel is located on the front door of the UPS. Through the operation and display panel, you can conduct the UPS operation control and query all the UPS parameters, UPS and battery states, and alarm message.

As shown in Figure 3-1, the operation and display panel provides LCD, menu buttons (F1 ~ F4、HELP)、LED indicators (inverter indicator and fault indicator ), control buttons (FAULT CLEAR, ON, OFF, ALARM CLEAR, EPO).



Figure 3-1 Operation and display panel

#### 3.1.1 LED Indicators

The LED indicators are composed of inverter indicator and fault indicator. Table 3-1 gives the indicators description.

Table 3-1 Description of LED indicators

LED	Color	State	Meaning
Inverter indicator	Green	Steady green	Load power is supplied by the inverter
		Flashing green	Inverter ON, starting up, synchronizing, or standing by (ECO mode)
		Off	Inverter not operating
Fault indicator	Red	Flashing red	General fault (such as no battery)
		Steady red	Serious fault (such as inverter fault)
		Off	No fault

#### 3.1.2 Audible Alarm (Buzzer)

The UPS activity is accompanied with the following two different kinds of audible alarms shown in Table 3-2.

Table 3-2 Audible alarm description

Sound	Meaning
One beep every second	UPS alarm, such as AC input failure
Continuous beep	UPS fault, such as fuse or hardware failure

### 3.1.3 Control Buttons

The operation and display panel provides five control buttons, which functions are described in Table 3-3.

Table 3-3 Description of control buttons

Control button	Silk screen	Description
EPO switch	EPO	Used to disconnect the load power, and close the rectifier, inverter, static bypass and battery
Inverter on	ON	Used to start the inverter
Inverter off	OFF	Used to close the inverter
Fault recovery on/off	FAULT CLEAR	Recover the UPS function (clear fault in advance)
Alarm sound silence on/off	ALARM CLEAR	When an audible alarm is active, pushing this button silences the audible alarm. Press this button again can restart the buzzer

### 3.1.4 LCD And Menu Buttons

The operation and display panel provides an LCD and five menu buttons (F1, F2, F3, F4, HELP). Table 3-4 gives the menu buttons function description.

Table 3-4 Menu key functions description

Key	F1	F2	F3	F4	HELP
Function 1	HOME	ESC Escape	Left	Right	Enter
Function 2			Up	Down	

LCD provides you with the user-friendly interface and the 320 × 240 dot matrix image display. The user-friendly and menu-driven LCD allows you to easily browse through the input, output, load and battery parameters, learn about the current UPS status and alarm message, perform functional setting and control operation. The LCD also stores up to 512 historical alarm records that can retrieve for reference and diagnosis.

## 3.2 LCD Screen Types

### 3.2.1 Start Screen

Upon UPS start, the UPS executes the system self-test, and the start screen will appear and remains about 15 seconds, as shown in Figure 3-2.

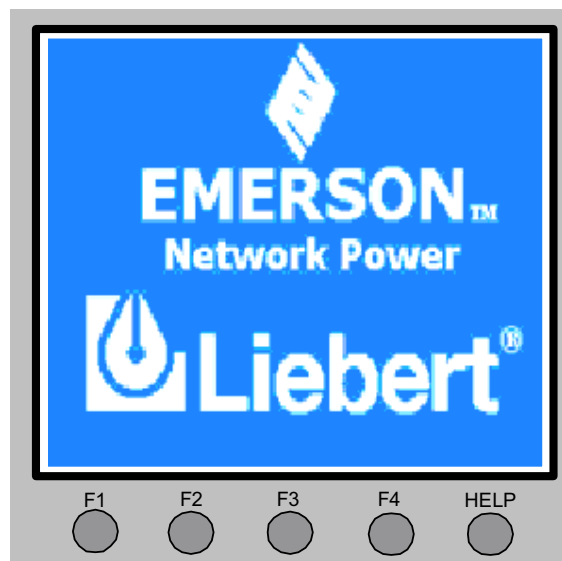

Figure 3-2 Start screen

### 3.2.2 Primary Screen

After the UPS system self-test, the primary screen shown in Figure 3-3 will appear. The primary screen is composed of four windows: system information window, data window, menu window and keypad window.

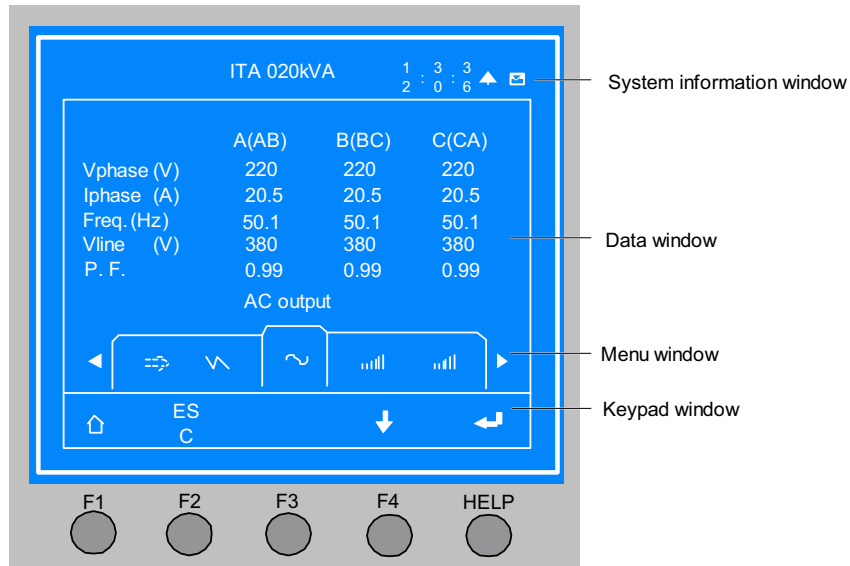

Figure 3-3 Primary screen

The current icons on top of the F1 ~ F4 and HELP menu buttons give the explanations of each key. Under any menu in primary screen, press the F1 button can return to the 'AC Output' menu. For details about the primary screen, refer to 3.3 Detailed Description Of Menu Items.

### 3.2.3 Default Screen

During the UPS operation, if there is no alarm within 2 minutes, the default screen shown in Figure 3-4 will appear. After a while, the LCD backlight will turn off. Press any menu key (F1 ~ F4, HELP), the primary screen will appear again.

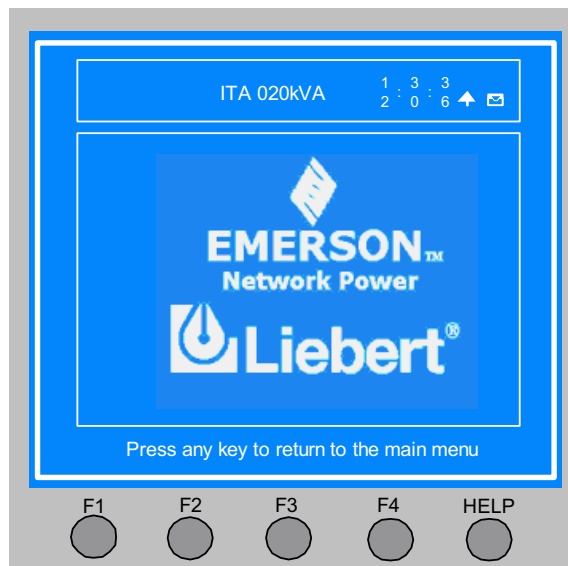

Figure 3-4 Default screen

### 3.3 Detailed Description Of Menu Items

The description in the following refers to the LCD primary screen shown in Figure 3-3.

#### System information window

The system information window displays the current time and the UPS name. You are not required for operating the information of this window. For details, see Table 3-5.

Table 3-5 System information window

Item	Explanation
ITA 020kVA	UPS name, which stands for Liebert ITA 20kVA UPS
12: 30: 36	Current time (format: 24 Hours, h: min: s)

#### Menu window and UPS data window

The menu window displays the menu name of the data window. The data window displays the items of the menu selected from the menu window. UPS parameters can be browsed and functions can be set through the menu window and data window. Details are given in Table 3-6.

Table 3-6 Menu window and data window

Menu	Item	Explanation
Main input	L-N voltage (V)	Phase voltage
	L-N current (A)	Phase current
	Frequency (Hz)	Input frequency
	L-L voltage (V)	Line voltage
	Power factor	Power factor
Bypass input	L-N voltage (V)	Phase voltage
	Frequency (Hz)	Bypass frequency
	L-L voltage (V)	Line voltage
AC output	L-N voltage (V)	Phase voltage
	L-N current (A)	Phase current
	Frequency (Hz)	Output frequency
	L-L voltage (V)	Line voltage
	Power factor	Power factor
Load	Sout (kVA)	Sout: Apparent power
	Pout (kW)	Pout: Active power
	Qout (kVAR)	Qout: Reactive power
	Loadlevel (%)	The percentage of the UPS rated load
	Crest factor	Output current crest factor
Parallel load	Sout (kVA)	Sout: Apparent power
	Pout (kW)	Pout: Active power
	Qout (kVAR)	Qout: Reactive power
Battery data	Battery voltage (V)	Battery bus voltage
	Battery current (A)	Battery bus current
	Battery temperature (°C)	Battery temperature (°C)
	Battery remain time (Min.)	Battery run time remaining
	Battery capacity (%)	Battery capacity (%), compared to the new battery
	Battery boost charging	Battery is boost charging
	Battery float charging	Battery is float charging
Battery is not connected	Battery is not connected	
Current records	(Current alarm)	Display current alarm. See Table 3-8 for UPS alarm message list
Historical records	(Historical alarm)	Display all historical alarms. See Table 3-8 for UPS alarm message list
Menu language	(Language selection)	Options are displayed in Chinese or English

Menu	Item	Explanation
Function settings	LCD contrast	Adjust the LCD contrast
	Date format	YYYY MM DD, DD MM YYYY and MM DD YYYY formats can be selected.
	Date & time	Set the date and time
	Comm1 baud rate	Set the communication baud rate of the USB port
	Comm2 baud rate	For internal communication only, can not be set
	Comm3 baud rate	Set the communication baud rate of the SNMP card port
	UPS address	This setting is suitable for RS485 communication
	Communication mode	Set the communication mode
	Callback times	If the communication mode of the SNMP card port is Modem, you can set alarm callback times here
	Phone No.1	If the communication mode of the SNMP card port is Modem, you can set phone No.1 here
	Phone No.2	If the communication mode of the SNMP card port is Modem, you can set phone No.2 here
	Phone No.3	If the communication mode of the SNMP card port is Modem, you can set phone No.3 here
	Command password	You can change the command password. Default: "123456"
	Battery capacity test	Battery capacity
	Battery cell	Set the battery cell. The setting options include: 30-cell, 32-cell, 34-cell, 36-cell, 38-cell, 40-cell
	Battery boost charge	Enabled or disabled
	Temperature compensation	Enabled or disabled
	Temperature sensor	Set the position of the temperature sensor. "Remote" only
	Battery group sharing	Set each single in parallel system to share the battery group or not
	Single/parallel	Set the single/parallel
	Parallel number	Set the parallel number
	Redundant number	Set the redundant number
	ECO mode	ECO function enabled
	Output frequency	Set the output frequency
	Output voltage system	Set the output voltage system
	LBS	LBS function enabled
3-in 3-out/3-in 3-out	Set the output system: 3-in 3-out/3-in 3-out This setting can only be carried out after the EPO operation. After the setting, you must power off the system, and confirm that the system actual connection mode complies with the setting. Power on again, and the setting can come into force	
Test command (start, stop battery, system test or forcing boost charge)	Battery maintenance test	The battery maintenance test will lead to the battery being partly discharged, for rough assessment of the battery capacity. The load must range from 20% ~ 100%
	Battery capacity test	The battery capacity test will lead to the battery being completely discharged, for accurate assessment of the battery capacity. The load must range from 20% ~ 100%
	System test	For UPS self-test. The user activates this function, 5 seconds later, a pop window will appear to show the result of this test
	Stop testing	Manually stop the test, including maintenance test, capacity test and system test
	Forcing charge	Manually conduct the forcing boost charge for battery
	Stop forcing charge	Manually stop the forcing boost charge for battery
System version	Monitor Version	Provide the monitor software version
	Rectifier Version	Provide the rectifier software version
	Inverter Version	Provide the inverter software version

### Keypad window

The function of menu buttons (F1 ~ F4 and HELP) is shown in icon mode for the current display screen.

### 3.4 Prompt Window

A prompt window is displayed during the operation of the system to alert you to certain conditions and/or to require your confirmation of a command. The prompts and meanings are given in Table 3-7.

Table 3-7 Prompts and meanings

Prompt	Meaning
Transfer with interrupt between bypass and inverter, confirm or cancel it when powering off for a while	Inverter and Bypass supplies are not synchronized and any load transfer between the supplies will cause a brief load interruption
This operation leads to output shutdown, confirm or cancel it	The bypass is in abnormal state, inverter shut down will cause the load power-off
Turn on more UPS to carry current load	The number of paralleled inverters already turned on is insufficient to carry the existing load
Battery will be depleted, confirm or cancel	Battery maintenance test discharges the battery 100%. This prompt appears to require your confirmation. Cancelling the test will end the test and transfers the UPS to Normal mode
System self-test is finished, everything is ok	No action required
System self-test is finished, please check the current warnings	Check the current alarm message
Enter control password	Required for battery or UPS test
Battery self-test condition is low, please check battery state and loadlevel	Battery test condition is not met. Please check whether the battery is in boost charge state and the load level is over 20%
Forcing charge condition is low, please check battery state	This prompt appears when you select the forcing charge command while the forcing charge condition is not met (such as no battery, charger failure)
Check the connection according to the settings, power-off takes effect, 3-phase (1-phase) output	After setting the menu option '3-in 3-out/3-in 1-out', you can power off the system completely, and then power on again after the wiring is changed according to the settings

### 3.5 UPS Alarm Message List

The following list gives the UPS alarm message list based on the 'Current records' and 'Historical records' menus in Table 3-8.

Table 3-8 UPS alarm message list

Alarm message	Description
Inverter comm. fail	Internal communication failure between the monitoring board and inverter
Rectifier comm. fail	Internal communication failure between the monitoring board and rectifier
Parallel comm. fail	The CAN communication between different UPSs within a parallel system fails. 1. Check if there are some UPSs not powered on in the parallel system. If so, power on these UPSs and check if the alarm disappears. 2. Press the FAULT CLEAR button
Battery fault	Battery detected faulty (Reserved)
Battery replaced	Battery test failed, Battery should be replaced
Battery low pre-warning	Before the end of discharge, battery undervoltage pre-warning should occur. After this pre-warning, battery should have the capacity for 3 minutes discharging with full load. The time is user-configured from 3 minutes to 60 minutes. Shut down the load in time
Battery stop discharge	Inverter turned off due to low battery voltage. Check the utility failure and try to recover it
Mains volt. abnormal	Mains Voltage exceeds the upper or lower limit and results in rectifier shutdown. Check the input line-to-neutral voltage amplitude of rectifier
Mains undervoltage	Mains voltage is undervoltage. Derate for running and check the input line voltage
Mains freq. abnormal	Mains frequency is out of limit range and results in rectifier shutdown. Check the input frequency
Rectifier block	Rectifier detected faulty. Rectifier shuts down. Battery discharges
Rectifier overtemp.	The temperature of heat sink is too high to keep the rectifier running. The UPS can recover automatically. Check the environment and ventilation
Battery charger fault	Battery charger is over voltage
Control power 1 fail	UPS operates but Control Power is not available
Mains phase reversed	Rectifier AC input phase sequence is reversed

Alarm message	Description
Rectifier over-current	Rectifier is over current
Soft start fail	Rectifier could not start due to low DC bus voltage
Bypass unable to trace	This alarm is triggered by an inverter software routine when the amplitude or frequency of bypass voltage is beyond the normal range. The amplitude threshold is fixed for $\pm 10\%$ rating. This alarm will automatically recover when the bypass voltage goes normal. 1. First verify that the bypass voltage and frequency displayed on the operator control and display panel is within the selected range. Note that the rated voltage and frequency are specified by the 'Output Voltage Level' and 'Output Frequency Level' respectively. 2. If the displayed voltage is abnormal, please verify the actual bypass voltage and frequency presented to the UPS. Check the external power if it is found to be faulty
Bypass protection	This alarm is triggered by an inverter software program when the amplitude or frequency of bypass voltage is too high or too low. The amplitude threshold is fixed for $\pm 10\%$ rating. This alarm will automatically recover when the bypass voltage goes normal. 1. First check if there are some relevant alarms, such as 'Bypass Phase Reverse', 'Input disconnect Fault'. If so, solve them first. 2. Then verify that the bypass voltage and frequency displayed on the LCD are within the limit. Note that the rated voltage and frequency are specified by the 'Output Voltage Level' and 'Output Frequency Level' respectively. 3. If the displayed voltage is abnormal, please verify the actual bypass voltage and frequency presented to the UPS. Check the external power if it is found to be faulty. If the utility is likely to trigger this alarm frequently, the bypass limit can be changed a little larger through the configuration software according to the user feedback
Inverter asynchronous	This alarm is triggered by an inverter software program when the inverter and bypass waveforms are misaligned by more than 6 degrees in phase. The amplitude threshold is fixed for $\pm 10\%$ rating. This alarm will recover automatically when the alarm condition disappears. 1. First check if the alarm 'Bypass Unable To Trace' or 'Bypass Protection'. If so, solve it first. 2. Verify the waveform of the bypass voltage. If it is too distorted, ask the user to verify it and seek any possible measurement
Inverter fault	Inverter output voltage beyond limits. Load transfers to bypass
Inverter overtemp.	The temperature of the inverter heat sink is too high to keep inverter running. This alarm is triggered by the signal from a temperature monitoring thermostat on the inverter bridge heat sink. The UPS will recover automatically after 5 minutes delay from the disappearance of the overtemperature signal. If the overtemperature condition is true, check the following items: 1. high ambient temperature. 2. blocked cooling airway. 3. any fan failure. 4. prolonged inverter overload
Fan fault	At least one of the cooling fans has failed
Inverter STS fail	At least one of the static switches of inverter side is open or short circuit. This fault is locked until power off
Bypass STS fail	At least one of the static switches of bypass side is open or short circuit. This fault is locked until power off
Operation invalid	Incorrect operation
Neighbor bypass SSTS fail	At least one of the static switches of single bypass side in parallel system is open or short circuit. This fault is locked until power off
Output fuse fail	At least one inverter output fuse blowou. The inverter shuts down, the load transfers to bypass
Unit over load	The UPS is confirmed to be overload when the load arises above 105% nominal rating. The alarm automatically resets once the overload condition is removed. 1. Confirm that the alarm is true by checking the load percent indicated on the LCD to determine which phase is being overloaded. 2. If the alarm is true, measure the actual output current to verify that the indications are valid. Disconnect unnecessary load and ensure the safety.
By. abnormal shutdown	Both bypass and inverter voltages unavailable. Load interruption
Inverter over current	Inverter pulse width modulation module overloaded
Bypass phase reverse	The phase sequence direction of bypass voltage is reversed. Normally, the phase of phase B lags 120 degrees behind phase A, and the phase of phase C lags 120 degrees behind phase B. Verify that the phase rotation of the bypass supply presented to the UPS is correct, and rectify it if it is found to be in error
Load impact transfers bypass	A transfer to bypass occurred due to a large step load. The UPS should recover automatically. Turn on connected equipment in sequential order to reduce the step loading of the inverter
Transfer time-out	The load is on bypass power due to excessive number of transfers that occurred within the last hour. The UPS will recover automatically and will transfer the load back to inverter power within an hour
Bus abnormal	DC input voltage to inverter beyond limits. Inverter shuts down. Load transfers to bypass

Alarm message	Description
DC bus over voltage	Rectifier and inverter were shut down because DC bus voltage is too high. Check whether there is a fault in rectifier side. If not, check whether there is an overload. After recovering the fault, restart the inverter
Bypass over current	Bypass current is over limit above 135% rating. The UPS just alarms and does nothing
Setting save error	History records not saved. (Reserved)
Fault of entering 缺零	AC mains input neutral line is not checked out
Protocol version clash	Firmware incompatibility between Monitor Board and Digital Signal Processor Board
Manual on	Manual Turn On through operator control and display panel
Manual off	Manual Turn Off through operator control and display panel
EPO	Press the EPO switch directly or receive the external EPO command
Transfer confirm	Prompt to press the Enter key to acknowledge that an interrupted load transfer to bypass will happen
Transfer cancel	Prompt to press the ESC key to avoid that an interrupted load transfer to bypass will happen
Fault clear	Press FAULT CLEAR
Alarm silence	Press ALARM CLEAR
Turn on fail	Inverter failed to turn on when INVERTER ON direct access key was pressed. This may be as a result of Invalid Operation (Maintenance bypass on) or DC bus or rectifier not ready
Alarm silence cancel	Press FAULT CLEAR or ALARM CLEAR
Bypass mode	The UPS is in Bypass mode
Normal mode	The UPS is in Normal mode
Battery mode	The UPS is in Battery mode
Check UPS output	The UPS is off and has no output
Battery float charging	Battery status (Float charge mode)
Battery boost charging	Battery status (Boost charge mode)
Battery discharging	Battery status (discharge mode)
Battery period testing	Automatic periodic battery maintenance discharge test (20% capacity discharge)
Batt. capacity testing	User initiated battery capacity discharge test (100% capacity discharge)
Batt. maint. testing	User initiated maintenance discharge test (20% capacity discharge)
UPS system testing	User initiated system test
Inverter in setting	Inverter starting up and synchronizing
Rectifier in setting	Rectifier starting up and synchronizing
Battery reverse	Reconnect the battery, check the battery connection
No battery	Check the battery and the battery wiring
Auto start	After UPS was shutdown at EOD, inverter auto starts when utility restore
REC FLASH UPDATE	Ongoing update of rectifier firmware
INV FLASH UPDATE	Ongoing update of inverter firmware
MONITOR FLASH UPDATE	Ongoing update of monitor firmware
DSP softwar error	Inverter software does not match the rectifier software
Note: When the alarm is caused through setting the software value by the Emerson authorized engineer, if you wish to change the setting values, please get in touch with the Emerson local customer service center	

## Chapter 4 UPS Operation Instructions

This chapter gives a detailed description of UPS operation procedures.

Refer to *Chapter 3 Operation And Display Panel* for all buttons operation and LED display in operation. During the operation, the buzzer alarm may appear, at this point, you should press the ALARM CLEAR button for audible alarm silence.



Warning: Hazard mains and/or battery voltage exists behind the protective cover

No user accessible parts are located behind the protective covers that require a tool for removal. Only the qualified service personnel are authorized to remove such covers.

### 4.1 UPS Start-up

The start-up procedures can be performed after the installation is finished, the system has been commissioned by authorized personnel and the external input switches are closed.



Warning

This procedure results in mains voltage being applied to the UPS output terminals. Confirm that the load power supply is safe, if there is a load to be connected with the UPS output terminal. Ensure that the load is isolated with the UPS output terminal, if the load is not ready for receiving the power supply.

#### 4.1.1 Normal Module Start-up Procedure

This procedure is suitable for UPS start-up when the UPS is in complete disconnection state. Procedures are as follows:

1. Close the output/input switch outside the UPS on by one.

At this point, LCD displays the start screen, and the rectifier starts. After the rectifier runs in normal state about 30s, the rectifier start is finished.

2. Press the ON button for 2 seconds.

At this point, the inverter starts, and the inverter indicators are flashing green. After the inverter runs in normal state, the UPS transfers from bypass state to inverter state. The inverter indicators turn green, and the UPS runs in Normal state.

#### 4.1.2 Battery Module Start-up Procedure

1. Check that the batteries have been well connected.
2. Press the battery cold start button on the UPS front panel (see Figure1-1).

At this point, LCD displays the start screen. After the rectifier start-up is finished, the fault indicator is off.

3. Press the ON button for 2 seconds, the UPS will run in Battery mode.

### 4.2 Transferring Procedures Between Operation Modes

#### 4.2.1 Transferring From Normal Mode To Battery Mode

In the event of mains failure, the UPS will switch to Battery mode. If you wish to switch the UPS from Battery mode to Normal mode, you should wait a few seconds for the mains input recovery. 10 seconds later, the rectifier will restart automatically, and the inverter will restore the power supply.

#### 4.2.2 Transferring From Normal Mode To Bypass Mode

In Normal mode, press the OFF for 2 seconds, you can switch the UPS to Bypass mode.



Note

In Bypass mode, the load accepts the power not from the pure power output by the inverter, but from the mains directly.

#### 4.2.3 Transferring From Bypass Mode To Normal Mode

In Bypass mode, press the ON button for 2 seconds. After the inverter runs in normal state, the UPS switches to Normal mode.

#### 4.2.4 Transferring From Normal Mode To Maintenance Bypass Mode

When the UPS is running in Normal mode, you can use this procedure to make the load switch from inverter output to maintenance bypass.



Caution

1. Before performing this procedure, you should check the LED information first, and make sure the bypass is normal and synchronizes with the inverter. Otherwise, it may result in the load power supply interruption for a while.
2. You should select the single POD options or prepare the maintenance bypass switch by yourself, so as to realize this function.

1. Press the OFF for 2 seconds.

The inverter indicators are off, and the buzzer alarms. The load switches to the static bypass, and the inverter shuts down.



Note

Press the ALARM CLEAR button can silence the alarm, but the alarm message of the the LCD is not disappeared until the alarm status is cleared.

2. Close the maintenance bypass switch on the single POD front panel, and the maintenance bypass can supply power to the load.



Warning

If you wish to maintain the UPS, you should wait 10 minutes for the internal DC bus capacitance voltage discharging.

3. Disconnect the main/bypass input/output switches.



Caution

1. When the UPS is in Maintenance Bypass mode, the load does not have the mains abnormal protection.
2. After the UPS switches to maintenance bypass, the UPS is not in operation, and the LCD is no display, and only the user terminal block of the single POD is electrified. Be careful when removes the UPS to be maintained.

### 4.3 Complete Shutdown Procedure

If you wish to shut down the UPS completely, the procedures in 4.2.4 *Transferring From Normal Mode To Maintenance Bypass Mode* should be followed, so as to transfer the UPS from Normal mode to Maintenance Bypass mode.

Disconnect the external input switch, if you wish to isolate the UPS from AC power.

## 4.4 EPO Procedure

There is an EPO switch on the UPS operation and display panel. The EPO button is designed to switch off the UPS in emergency conditions (such as fire, flood, and so on). The system will turn off the rectifier, inverter and stop powering the load immediately (inverter and bypass included), and the battery stops charging or discharging.

If the mains input is present, the UPS control circuit will remain active; however, the output will be turned off. To remove all mains power from the UPS, the external input switch should be disconnected.

## 4.5 Auto Restart

When the mains power failure, the UPS draws power from the battery to supply the load until the batteries are depleted. Then the UPS will shut down.

The UPS will automatically restart and recover output power:

- After the mains power is restored.
- The UPS Auto Restart function is enabled.
- After the Auto Restart is delayed (default: 10 minutes). During the Auto Restart delay, the UPS will charge the battery to provide a safety margin for equipment shutdown if input power fails again.

If the Auto Restart function is disabled, you can restart the UPS manually by pressing the FAULT CLEAR button.

## 4.6 UPS Reset Procedure

The EPO action or the following reasons such as inverter overtemperature, power-off overload, battery overvoltage and excessive switching may result in the UPS power-off. Once all appropriate measures have been taken to correct the problem indicated by the alarm message appearing on the LCD, you can carry out the following procedures to restore the UPS to normal operation state.

1. Press the FAULT CLEAR button to make the system exit the EPO state.
2. Press the ON button for 2s.



Note

1. The rectifier restarts, and the bypass supplies power to the load. When the rectifier starts, the fault indicator flashes. When the rectifier runs in normal operation (about 30 seconds later), the fault indicator will turn off.
2. 5 minutes after the overtemperature signal disappears, that is, when the overtemperature fault is eliminated, the rectifier will automatically start.
3. After the EPO button is pressed, if the mains input is disconnected, the UPS will shut down completely. When the mains input is available, the UPS will start and run in Bypass mode, and also the output is available.

## 4.7 Language Selection

The LCD menus are available in two languages: Chinese, English.

Procedures for selecting the language:

1. From the 'AC Output' menu, press F3 or F4 (left or right arrow) to select the 'Language' menu.
2. Press F5 (Enter) to move the cursor to the UPS Data Window of the LCD.
3. Use F3 and F4 (up and down arrows) to select the required language.
4. Press F5 (Enter) for confirmation.
5. Return to the 'AC Output' menu by repeatedly pressing F2 (ESC). At this point, all texts on the LCD will be displayed in the selected language.

## 4.8 Changing Current Date And Time

Procedures for changing the system date and time:

1. From the 'AC Output' menu, press F3 or F4 (left or right arrow) to select the 'Settings' menu.
2. Press F5 (Enter) to move the cursor to the UPS Data Window of the LCD.
3. Use F3 and F4 (up and down arrows) to select 'Date And Time' option, then press F5 (Enter).
4. Position the cursor on the row in which the date and time are displayed, then press F5 (Enter).
5. Use F3 or F4 (up or down arrows), and enter the current time and date information.
6. Press F5 (Enter) for confirmation, and then press F2 (ESC) to return to the 'AC Output' menu.

## 4.9 Control Password

The system provides the password protection for the UPS operation control. The default password is '123456'. Only through the password verification can you conduct the UPS and battery test operation.

## Chapter 5 Maintenance

This chapter focuses on the UPS maintenance, including the fan maintenance, battery maintenance, UPS cleaning, UPS state check, UPS function check.

### 5.1 Fan Maintenance

The UPS fans are expected to run for 20000 hours ~ 40000 hours continuously. The higher the ambient temperature, the shorter the fan life is. During the UPS operation, please verify the fan status once every half year by confirming that air blows out from the ventilation holes on the rear panel.

### 5.2 Battery Maintenance

The internal battery module of the UPS is sealed, lead-acid, maintenance-free battery. The battery life depends on the ambient temperature, charge and discharge times. High ambient temperature and deep discharge shortens the battery life.

To ensure the battery life, it is required to:

- Keep the ambient temperature between 15°C and 25°C.
- Prevent small current discharge. Continuous battery operation time exceeding 24 hours is strictly prohibited.
- Charge the battery for at least 12 hours, if the battery hasn't been charged for three months at specified ambient temperature, or two months at high ambient temperature.



Note

1. Never short circuit the battery terminals, which will result in fire.

2. Never open the battery, as the electrolyte is harmful to human body. In the event of inadvertent contact of the electrolyte, wash the affected area immediately with plenty of clean water and go to see the doctor.

### 5.3 Cleaning UPS

Clean the UPS periodically, especially the ventilation holes, to ensure free airflow inside the UPS. If necessary, clean the UPS with a vacuum cleaner. Confirm that the ventilation holes are unobstructed.

### 5.4 Checking UPS State

It is recommended to check the UPS operation status once every half year.

Procedures are as follows:

1. Check if the UPS is faulty: Is the FAULT indicator on? Is the UPS giving any alarm?
2. Check if the UPS is operating in Bypass mode: Normally, the UPS operates in Normal mode; if it is operating in Bypass mode, find out the reason, such as operator intervention, overload, internal fault, and so on.
3. Check if the battery is discharging: When AC mains is normal, the battery should not discharge; if the UPS operates in Battery mode, you should find out the reason, such as mains failure, battery test, operator intervention, and so on.

### 5.5 Checking UPS Functions



Note

UPS functions check procedures may cause power interruption to load!

It is recommended to check the UPS functions once every half year.

Backup the load data before conducting the UPS functions check. Procedures are as follows:

1. Press the OFF button to check if the buzzer beeps, indicators are on and the LCD display is normal.
2. Press the ALARM CLEAR button to check again if the indicators are on, the LCD display is normal and the UPS has switched to the inverter mode.

## Appendix 1 Battery Module

### Appearance

The protective panel has been installed at the factory to avoid the damage to the battery module during the transportation. Remove the six fixing screws to take off the protective panel after the battery module arrival. The appearance of the battery module is shown in Figure 1.

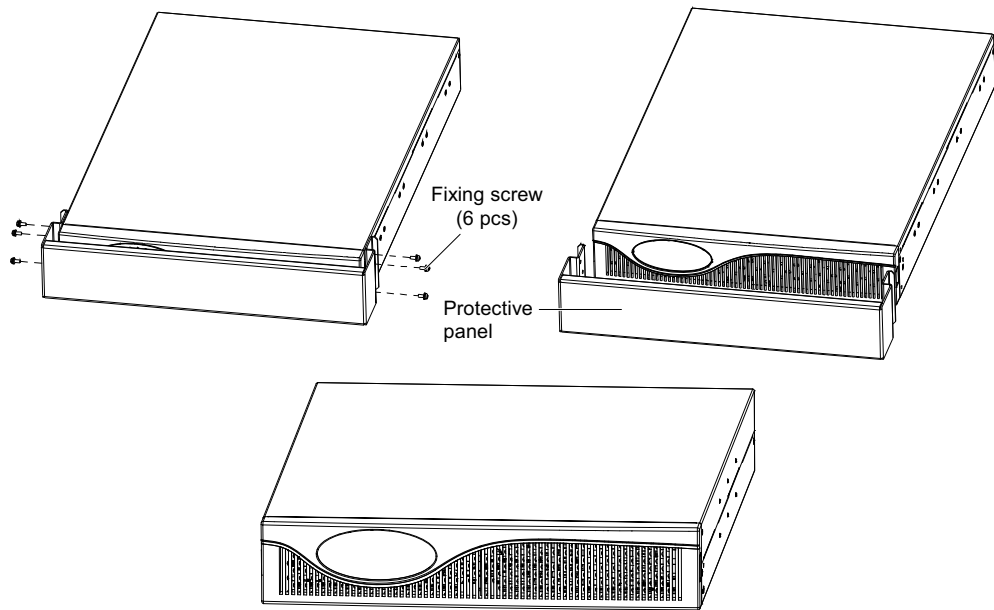

Figure 1 Appearance of the battery module

### Rear panel

Operation panel on the front panel of the battery module is not available. The battery module provides battery ports, battery fuse box and ventilation holes on the rear panel, as shown in Figure 2.

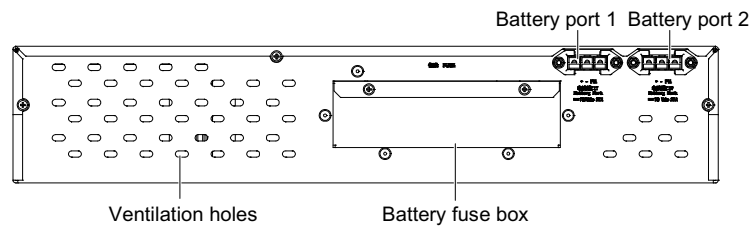

Figure 2 Rear panel of the battery module

### Replacing battery fuse

If the battery internal fuse is damaged, loosen the protective cover of fuse box on the battery module rear panel and replace the damaged fuse with a new one, then tighten the fixing screws of the protective cover of fuse box to prevent electric shock risk during the UPS operation, as shown in Figure 3.

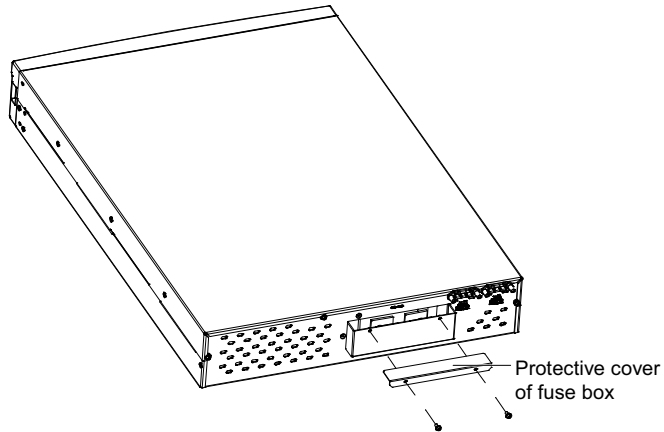

Figure 3 Schematic diagram of replacing fuse



Note

1. The battery loop and AC input are not insulated, a hazardous voltage may exist between the battery ports and ground, so it is prohibited to touch them for avoiding electric risk.
2. The length of the standard battery cable delivered with the battery module is 0.5m. If you need more length cable, please consult the dealer.

## Appendix 2 Optional Part List

The optional part list is given in Table 1.

Table 1 Optional part list

Optional part	Type	Remark
Communication options	UF-SNMP810	SNMP card assembly used in Intellislot UPS - ROHS
	UF-DRY320	Dry contact extended card used in UPS - {R5}
	UF-DRY310	Dry contact card and its assembly used in UPS - {R5}
	UF-RS485	RS232 to 485 component
	UFMOD21Z1	MODBUS assembly used in UPS (UFMOD21Z1)-{R5}
POD	UF-POD3U20K10	3-in 3-out/3-in 3-in 1-out rack model 20kVA smart UPS single POD
	UF-POD6U20K11	3-in 3-out/3-in 3-in 1-out rack model 20kVA smart UPS 1 + 1 parallel POD
Guide rail/rack	DMBM4.115.331	Use in rack installation mode
Battery module	U16-07C1	A battery cabinet with one-layer
Battery cable components		Use in battery module selection
Battery cabinet with two-layer	U20-24C2	Use in battery preparation by the user
Battery cabinet with three-layer	U20-38C3	Use in battery preparation by the user