

Contents

Chapter 1 Product Introduction	1
1.1 Product Specifications	1
1.2 Single POD	1
1.3 1 + 1 Parallel POD	2
1.3.1 1-In1-Out 1 + 1 Parallel POD	2
Chapter 2 Installation Of Single POD	4
2.1 Mechanical Installation	4
2.2 Connecting Cables	6
2.2.1 Selecting Cables	6
2.2.2 Connecting Cables Between POD And UPS	7
2.2.3 Connecting I/O Cables Of POD	8
2.2.4 Connecting Cables Between UPS And Battery Module	8
Chapter 3 Installation Of 1 + 1 Parallel POD	9
3.1 Mechanical Installation	9
3.2 Connecting Cables	12
3.2.1 Selecting Cables	12
3.2.2 Connecting Cables Between POD And UPS	12
3.2.3 Connecting Parallel Cables Of UPSs	13
3.2.4 Connecting I/O Cables Of POD	13
3.2.5 Connecting Cables Between UPS And Battery Module	14
3.3 Commissioning	14
Chapter 4 Parallel System Operation	15
4.1 Commissioning Parallel System	15
4.1.1 Check Before Start-Up	15
4.1.2 Parallel System Parameters Setting	15
4.1.3 Power-On Commissioning For Parallel System	15
Appendix 1 LCD Parameters Setting	18
Appendix 2 Hazardous Substances And Content	20

Chapter 1 Product Introduction

The Liebert® ITA2 5kVA/6kVA UPS power distribution unit (POD for short) is an option of the 5kVA/6kVA UPS (UPS for short), which can provide safe and reliable power distribution function for users.

The POD includes a POD and 1 + 1 parallel POD. The 1 + 1 parallel POD adopts a 1-in 1-out mode. The POD is used together with the parallel UPS respectively.

This chapter introduces the product specifications, appearance and panel of the POD.

1.1 Product Specifications

The product specifications are listed in Table 1-1.

Table 1-1 Product specifications

Product model	Product number	Product name	Dimension (W × H × D, mm)	Weight (kg)
ITA 05K00POD01	02010011	Single POD	430*85*500	8.32/11.5
ITA 05K00POD02	02010012	1-in 1-out 1+1 parallel POD	430*85*500	9/13

1.2 Single POD

The appearance of the single POD is shown in Figure 1-1.

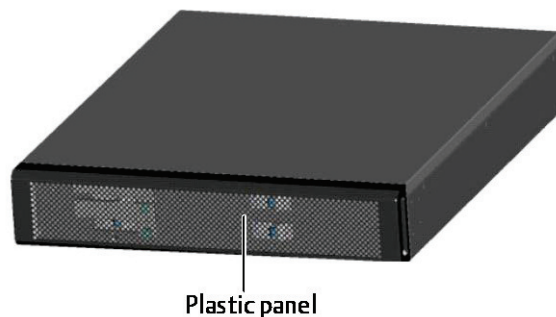

Figure 1-1 Appearance of single POD

Remove the plastic panel to reveal the front panel of the single POD, as shown in Figure 1-2.

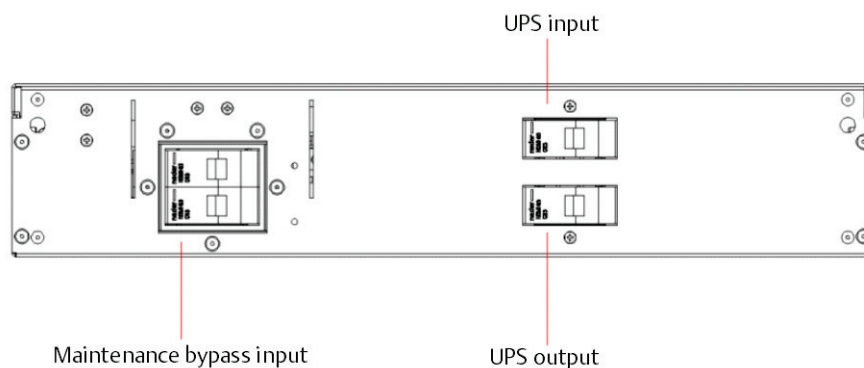

Figure 1-2 Front panel of the single POD

The rear panel of the single POD is shown in Figure 1-3.

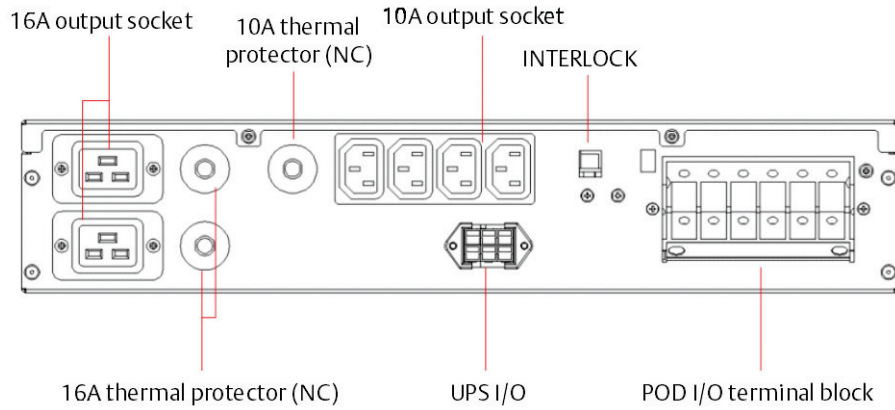



Figure 1-3 Rear panel of the single POD

	<p>Note</p> <p>1. The 10A output sockets (see Figure 1-3, one piece, specification: C13). The load capability of each 10A output socket is 10A, and the load capability of each row of the 10A output socket is also 10A.</p> <p>2. The 16A output sockets (see Figure 1-3, totally two) are 1-phase 3-core sockets. The load capability of each 16A output socket is 16A, and the total load capability of the two 16A output sockets is also 16A.</p>
---	--

1.3 1 + 1 Parallel POD

1.3.1 1-In1-Out 1 + 1 Parallel POD

The appearance of the 1-in 1-out 1 + 1 parallel POD is shown in Figure 1-4.

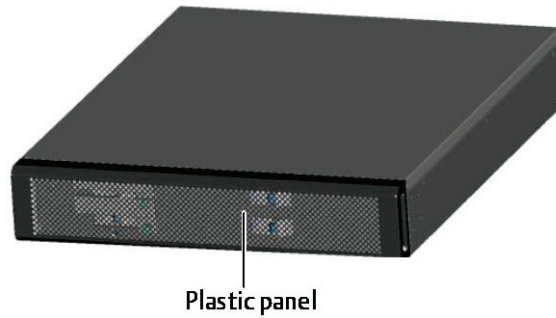

Figure 1-4 Appearance of the 1-in 1-out 1 + 1 parallel POD

Remove the plastic panel to reveal the front panel of the 1-in 1-out 1 + 1 parallel POD, as shown in Figure 1-5.

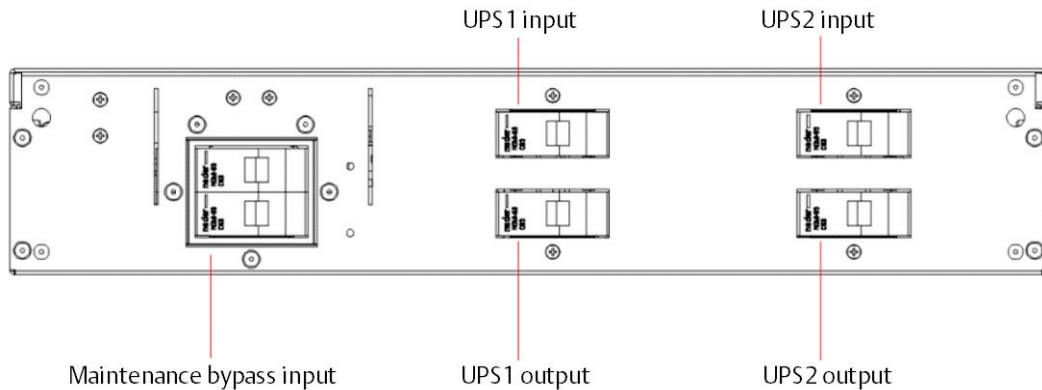

Figure 1-5 Front panel of the 1-in 1-out 1 + 1 parallel POD

The rear panel of the 1-in 1-out 1 + 1 parallel POD is shown in Figure 1-6.

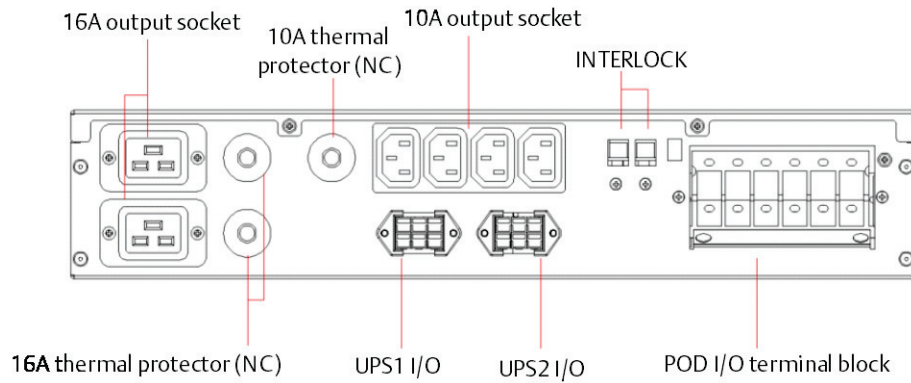

Figure 1-6 Rear panel of the 1-in 1-out 1 + 1 parallel POD



Note

1. The 10A output sockets (see Figure 1-3, one piece, specification: C13). The load capability of each 10A output socket is 10A, and the load capability of each row of the 10A output socket is also 10A.
2. The 16A output sockets (see Figure 1-3, totally two) are 1-phase 3-core sockets. The load capability of each 16A output socket is 16A, and the total load capability of the two 16A output sockets is also 16A.

Chapter 2 Installation Of Single POD

This chapter introduces the mechanical installation and cable connection of the single POD.



Note

The POD mentioned in this chapter is the single POD.

2.1 Mechanical Installation



Note

1. Only Emerson-authorized personnel shall install and operate the POD.
2. Unreliable connection that does not meet the requirements of the PE cables will lead to electromagnetic interference (EMI), a fire or electric shock.
3. The plastic panel of the POD cannot support weight. Remove the plastic panel first when the POD is installed or removed.

The single POD uses rack installation mode, the installation procedures are as follows:

1. Use eight M4 × 10 screws to fix two brackets (accessories) respectively on both sides of the POD front panel, as shown in Figure 2-1.

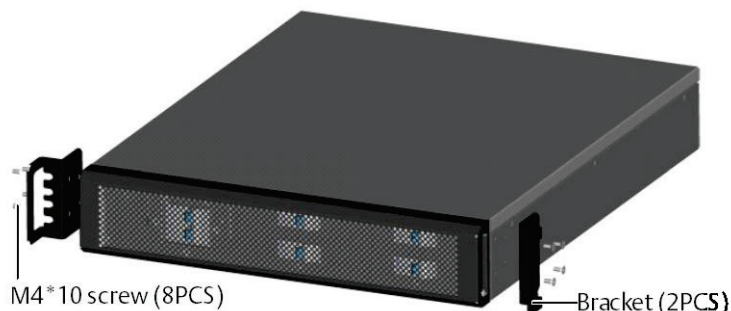

Figure 2-1 Installing brackets



Note

It is prohibited to move the POD through the brackets.

2. Install the guide rails.

1) Take out the guide rails (one left guide rail and one right guide rail), guide rail screws and panel screws from the package, distinguish the left guide rail and the right guide rail according to Figure 2-2, and confirm their retractable function respectively.

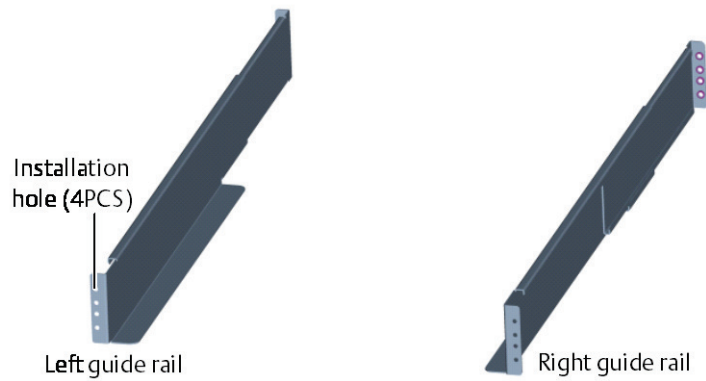

Figure 2-2 Appearance of the guide rails

Figure 2-3 is the guide rail screw.



Figure 2-3 Appearance of the guide rail screw

2) Adjust the length of the guide rail according to the dimensions of the rack.

3) Align the installation holes of the guide rail with the square holes of the rack, fix the guide rail onto the rack through the provided guide rail screws, the left guide rail and the right guide rail need four guide rail screws respectively, as shown in Figure 2-4.

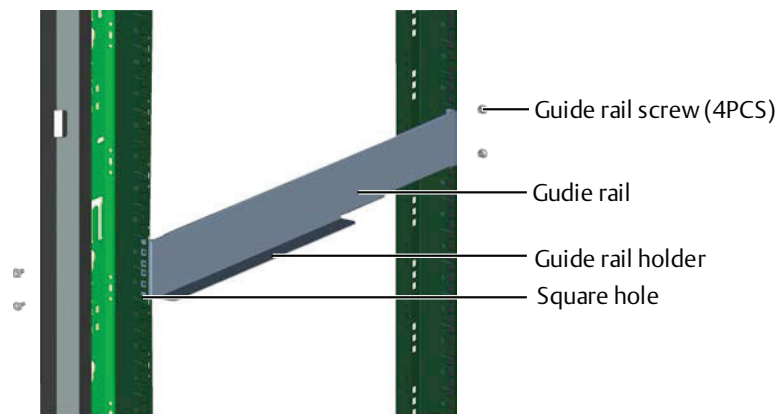

Figure 2-4 Installing the guide rail

 **Note**

1. The guide rail holder must be close to the front of the rack.
2. Each end of one guide rail has six installation holes, do not use the two installation holes in the middle when fixing the guide rail. It is recommended to use the top and bottom installation holes (from top to bottom, installation hole 1 and installation hole 6).

The guide rail installation is finished, as shown in Figure 2-5.

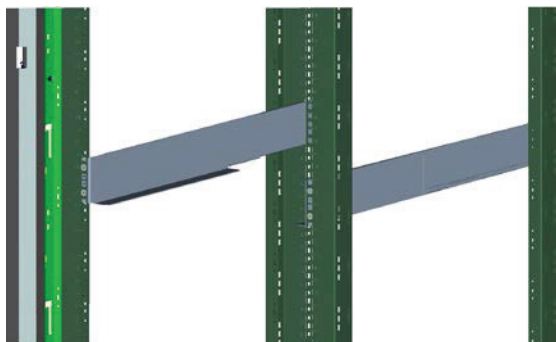

Figure 2-5 Guide rail installation complete

3. Place the POD onto the guide rails of the rack, and push the POD completely into the rack. Use four panel screws (M6 × 16) to fix the POD on the rack through the brackets, as shown in Figure 2-6.

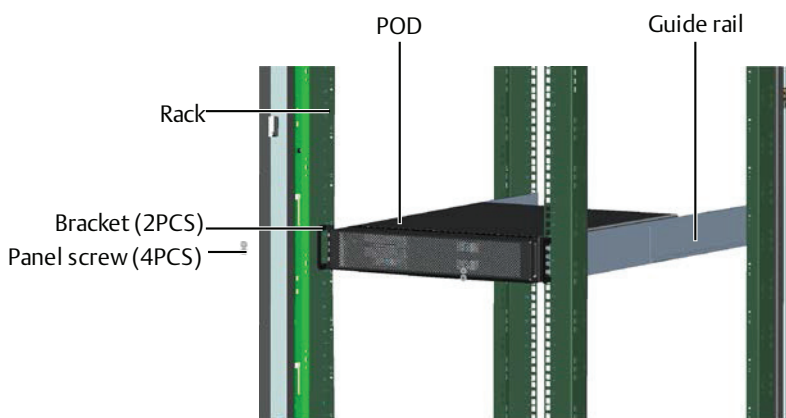



Figure 2-6 Installing the POD

	Note
When the POD is installed with battery modules and UPSs, the battery modules must be installed at the bottom, the UPSs in the middle and the POD at the top to facilitate cable connection and operation.	

2.2 Connecting Cables

2.2.1 Selecting Cables

Before connecting the I/O cables of the single POD, choose the cables according to the actual requirements. A protective MCB must be connected in series between the input end and the output end of the POD. The I/O cables and the MCBs must meet the requirements listed in Table 2-1.

Table 2-1 Requirements of the I/O cables and the MCBs

Name	PE cable cross-sectional area	Input cable cross-sectional area	Output cable cross-sectional area	Input MCB	Output MCB
Single POD	20mm ²	AWG6	AWG12	50A	50A

The cables between the UPS and the POD are delivered with the product.

2.2.2 Connecting Cables Between POD And UPS



Note

1. Before connecting the cables between the POD and the UPS, make sure that all the MCBs on the POD front panel are open, and paste a warning label to avoid misoperation on the MCBs by irrelevant person.
2. Unreliable connection that does not meet the requirements of the PE cables will lead to electromagnetic interference (EMI), a fire or electric shock.
3. When connecting the cables, connect the UPS end first, and then connect the POD end.

1. Take out the cables shown in Figure 2-7 from the POD package.

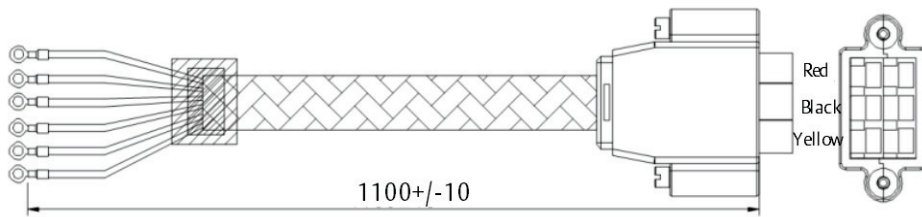

Figure 2-7 Single POD I/O cable A (UPS)

2. Use the cable A to connect the POD to the UPS according to Table 2-2 ~ Table 2-3.

Table 2-2 Cable connection between the POD and the UPS

POD	UPS
Insert the cable marked with UPS to the input and output ports of the UPS	UPS I/O terminal block

Table 2-3 Connecting cable A to UPS I/O terminal block (single POD)

Mark of cable	Silk-print of the UPS I/O terminal block
Input -PE	AC INPUT PE
Input -N	AC INPUT N
Input -L	AC INPUT L
Output -L	AC OUTPUT L
Output -N	AC OUTPUT N
Output -PE	AC OUTPUT PE

The cable connection between the single POD and the UPS is shown in Figure 2-8.

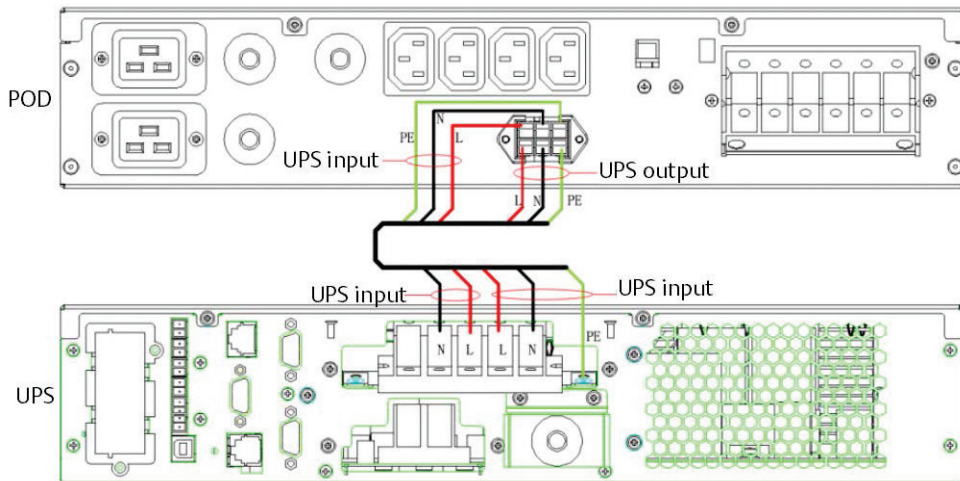

Figure 2-8 Cable connection between the single POD and the UPS

2.2.3 Connecting I/O Cables Of POD

The connection procedures for the POD input cables are as follows:

For the single POD, connect the mains input cables L, N, PE to the corresponding terminals on the I/O terminal block of the POD respectively, as shown in Figure 2-9.

The POD output ports include: 10A output sockets, 16A output sockets and output terminals on the I/O terminal block of the POD on the rear panel of the POD.

The connection procedures for the POD output cables are as follows:

1. Connect the output cables L, N, PE to the corresponding terminals on the I/O terminal block of the POD respectively, as shown in Figure 2-9.
2. Connect the other end of the output cables to the load.

The I/O cable connection of the single POD is shown in Figure 2-9.

 **Note**

1. An upstream protective MCB must be connected in series between the input end and the output end of the POD.
2. Confirm that the PE cable connection is reliable.

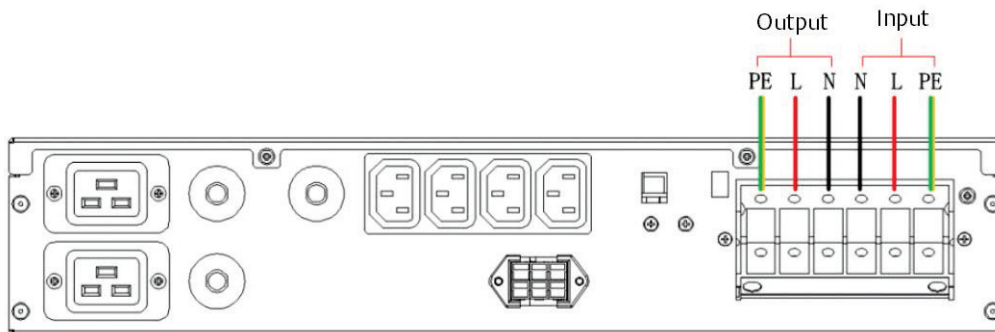

Figure 2-9 I/O cable connection of the single POD

2.2.4 Connecting Cables Between UPS And Battery Module

Refer to *Liebert1® ITA2 5kVA~20kVA UPS User Manual* for the cable connection between the UPS and the battery module.

Chapter 3 Installation Of 1 + 1 Parallel POD

This chapter introduces the mechanical installation, cable connection and commissioning of the 1 + 1 parallel POD.



Note

The POD mentioned in this chapter is the 1 + 1 parallel POD.

3.1 Mechanical Installation



Note

1. Only Emerson-authorized personnel shall install and operate the POD.
2. Unreliable connection that does not meet the requirements of the PE cables will lead to electromagnetic interference (EMI), a fire or electric shock.
3. In the 1 + 1 parallel system, the parallel system only provides one UPS load capacity, and one UPS is redundant to provide power supply.
4. The plastic panel of the POD cannot support weight. Remove the plastic panel first when the POD is installed or removed.

The 1 + 1 parallel POD uses rack installation mode, the installation procedures are as follows.

1. Use six M4 × 10 screws to fix two brackets (accessories) respectively on both sides of the POD front panel, as shown in Figure 3-1.



Figure 3-1 Installing brackets



Note

It is prohibited to move the POD through the brackets.

2. Install the guide rails.

1) Take out the guide rails (one left guide rail and one right guide rail), guide rail screws and panel screws from the package, distinguish the left guide rail and the right guide rail according to Figure 3-2, and confirm their retractable function respectively.

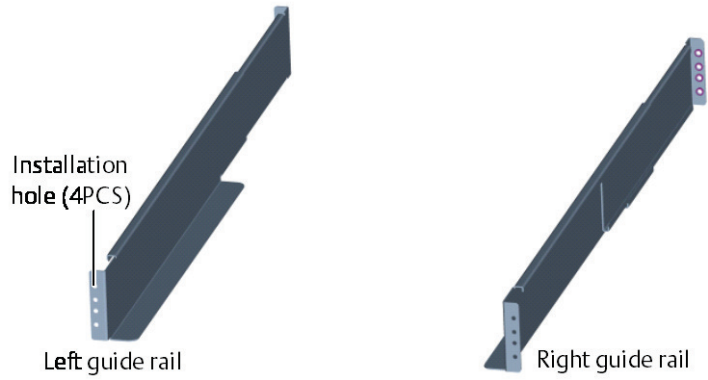

Figure 3-2 Appearance of the guide rails

Figure 3-3 is the guide rail screw.



Figure 3-3 Appearance of the guide screw

- 2) Adjust the length of the guide rail according to the dimensions of the rack.
- 3) Align the installation holes of the guide rail with the square holes of the rack, fix the guide rail onto the rack through the provided guide rail screws, the left guide rail and the right guide rail need four guide rail screws respectively, as shown in Figure 3-4.

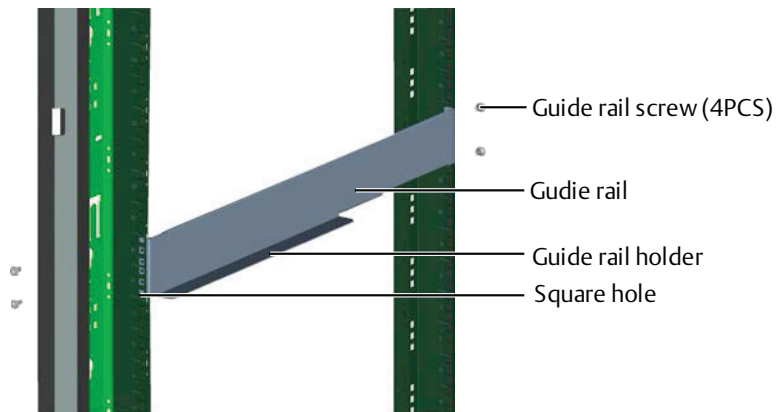



Figure 3-4 Installing the guide rail

 **Note**

1. The guide rail holder must be close to the front of the rack.
2. Each end of one guide rail has six installation holes, do not use the two installation holes in the middle when fixing the guide rail. It is recommended to use the top and bottom installation holes (from top to bottom, installation hole 1 and installation hole 6).

The guide rail installation is finished, as shown in Figure 3-5.

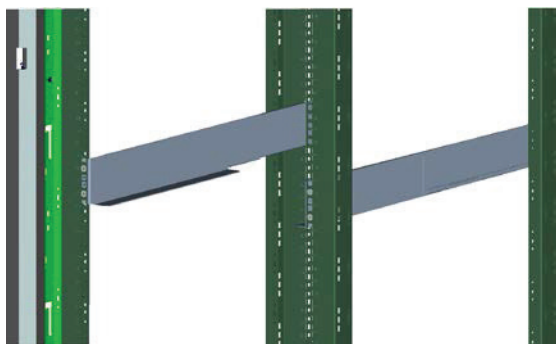

Figure 3-5 Guide rail installation complete

3. Place the POD onto the guide rails of the rack, and push the POD completely into the rack. Use four panel screws (M6 × 16) to fix the POD on the rack through the brackets, as shown in Figure 3-6.

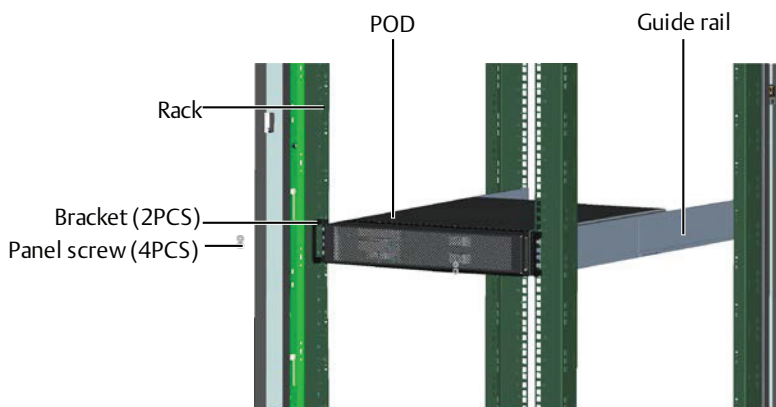



Figure 3-6 Installing the POD

 Note
When the POD is installed with battery modules and UPSs, the battery modules must be installed at the bottom, the UPSs in the middle and the POD at the top to facilitate cable connection and operation.

The standard installation of the 1 + 1 parallel system is shown in Figure 3-7.

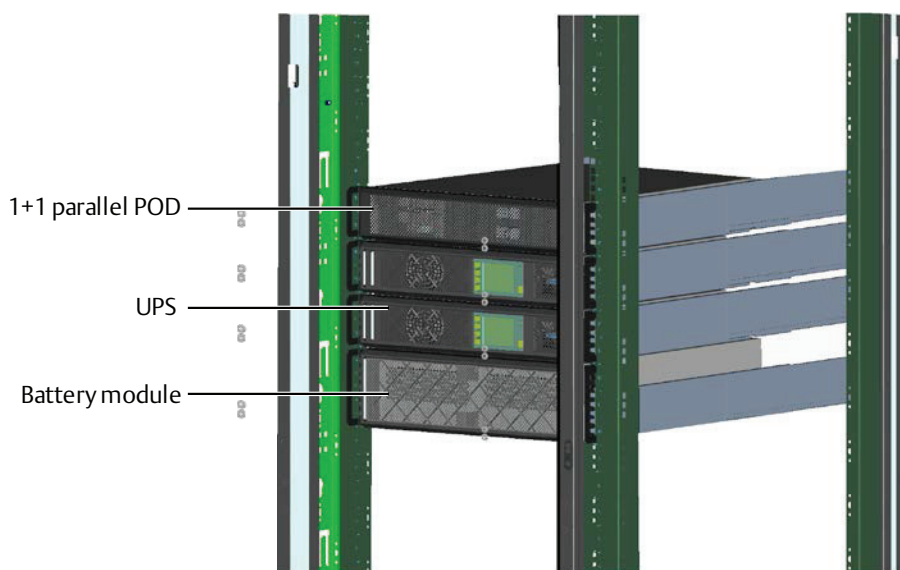

Figure 3-7 Standard installation of the 1 + 1 parallel system

3.2 Connecting Cables

3.2.1 Selecting Cables

Before connecting the I/O cables of the 1 + 1 parallel POD, choose the cables according to the actual requirements. A protective MCB must be connected in series between the input end and output end of the POD. The I/O cables and MCBs should meet the requirements listed in Table 3-1.

Table 3-1 Requirements of the I/O cables and the MCBs

Name	PE cable (CSA)	Input cable (CSA)	Output cable (CSA)	Input MCB	Output MCB
1-in 1-out 1 + 1 parallel POD	20mm ²	AWG6	AWG12	50A	50A

The cables between the UPS and the POD are delivered with the product.

3.2.2 Connecting Cables Between POD And UPS

 Note
<ol style="list-style-type: none"> 1. Before connecting the cables between the POD and the UPS, make sure that all the MCBs on the POD front panel are open, and paste warning label to avoid misoperation on the MCBs by irrelevant person. 2. Unreliable connection that does not meet the requirements of the PE cables will lead to electromagnetic interference (EMI), a fire or electric shock. 3. When connecting the cables, connect the UPS end first, and then connect the POD end.

1. Take out the cable shown in Figure 3-8 from the POD package.

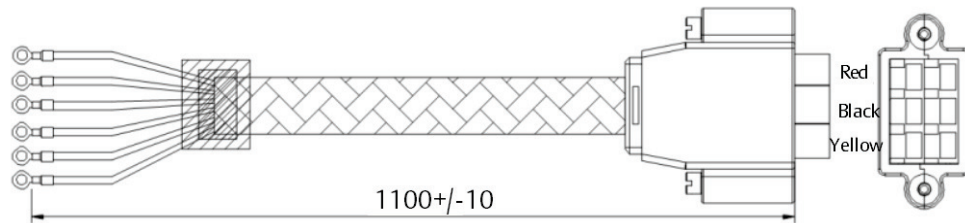

Figure 3-8 I/O cable A (UPS*2)

2. Use the two cables A to connect the POD to the UPS according to Table 3-2 and Table 3-3.

Table 3-2 Cable connection between the POD and the UPS

POD	UPS
Insert the cable E or the cable F marked with UPS to the input and output ports of the UPS	UPS I/O terminal block

Table 3-3 Connecting the cable A to the UPS I/O terminal block

Mark of cable	Silk-print of the UPS I/O terminal block
Input -PE	AC INPUT PE
Input -N	AC INPUT N
Input -L	AC INPUT L
Output -L	AC OUTPUT L
Output -N	AC OUTPUT N
Output -PE	AC OUTPUT PE

The cable connection between the 1 + 1 parallel POD and the UPS is shown in Figure 3-9.

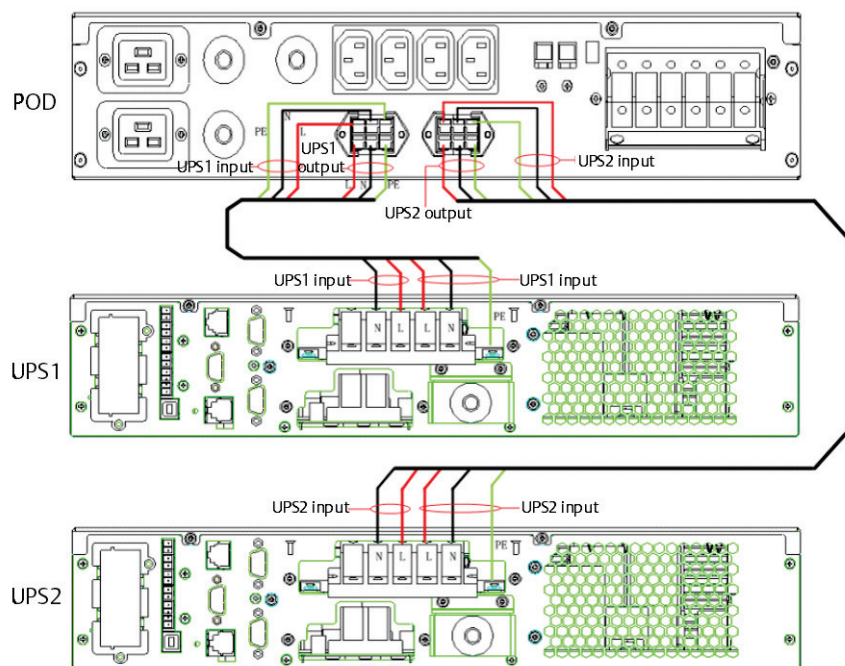

Figure 3-9 Cable connection between the 1 + 1 parallel POD and the UPS

3.2.3 Connecting Parallel Cables Of UPSs

The 1 + 1 parallel system needs two parallel cables (accessory). Parallel cable connection methods: Take out the parallel cables from the POD accessories, find the UPS parallel ports, and connect the parallel cables, as shown in Figure 3-10.

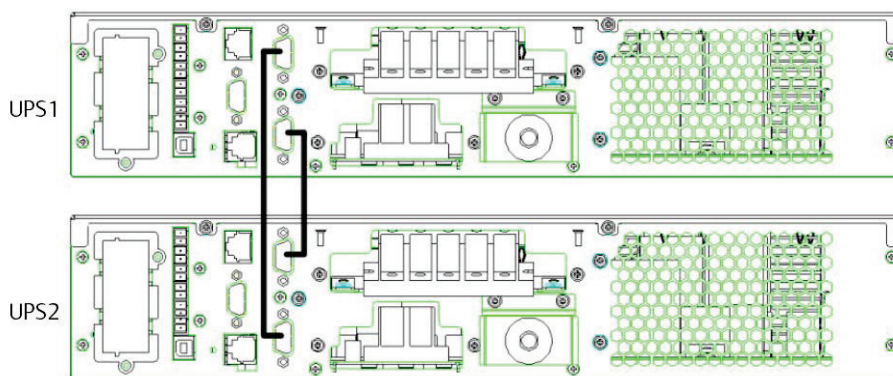

Figure 3-10 Parallel cable connection of the UPSs

3.2.4 Connecting I/O Cables Of POD

Connection methods of the input cables:

For 1 + 1 parallel POD, connect the mains input cables (L, N, PE) to the corresponding terminals on the I/O terminal block of the POD respectively, as shown in Figure 3-11.

The POD output ports include: 10A output sockets, 16A output sockets and output terminals of the I/O terminal block of the POD on the rear panel of the POD.

The connection procedures for the POD output cables are as follows:

1. Connect the output cables (L, N, PE) to the corresponding terminals on the I/O terminal block of the POD respectively, as shown in Figure 3-11.

2. Connect the other end of the output cables to the load.

The I/O cable connection of the 1 + 1 parallel POD is shown in Figure 3-11.

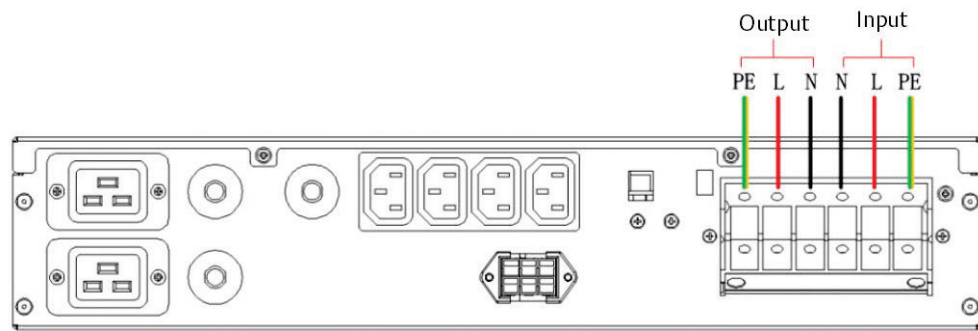

Figure 3-11 I/O cable connection of the 1 + 1 parallel POD



Note

1. An upstream protective MCB must be connected in series between the input end and the output end of the POD.
2. Confirm that the PE cable connection is reliable.

3.2.5 Connecting Cables Between UPS And Battery Module

Refer to *Liebert[®] ITA2 5kVA~20kVA UPS User Manual* for the cable connection between the UPS and the battery module.

3.3 Commissioning



Note

Refer to *Liebert[®] ITA2 5kVA~20kVA UPS User Manual* for the start-up and commissioning procedures of the 1 + 1 parallel POD.

Chapter 4 Parallel System Operation

4.1 Commissioning Parallel System

4.1.1 Check Before Start-Up

1. Check and confirm that power distribution mode of the UPS and the 1 + 1 parallel POD (if configured) is correct; that connections of the power cables and the signal cables are correct and there is no short circuit.
2. Check that the battery installation and cable connection is correct and there is no short circuit.
3. Check all the working status of the parallel system, ensure that the phase sequence of the mains, bypass and output of each UPS is correct and consistent, that the connection of the parallel cable is reliable, and that the user load is not connected during power-on.
4. Measure and confirm that the mains voltage and frequency are normal.
5. The output terminals of the UPS and the 1 + 1 parallel POD (if configured) are energized upon the start-up. If the load is connected with the output terminals, make sure that the power to the load is safe.



Warning

The output terminals of the UPS and the POD (if configured) will be live upon start-up. When bypass of the single UPS in the parallel system is not consistent, the system fault may occur, check and confirm the bypass before power-on.

4.1.2 Parallel System Parameters Setting

The parallel parameters for all the UPSs in the parallel system should be set, as shown in Figure 4-1.

Output	Battery	Parallel	
Voltage selection		220V	
Frequency selection		Auto,Bypa...	
Run mode		Normal	
Redundant		Yes	
System parallel num		1	
Output phase No.		1 phase	
Sync parallel parameters			

Figure 4-1 Settings for parallel parameters

The user can change these settings according to actual needs, refer to *Appendix 1 LCD Parameters Setting* for details. After the change, press the last item 'Sync parallel parameters' to validate the setting.

4.1.3 Power-On Commissioning For Parallel System

1. Set the parallel parameters of each UPS in the parallel system, then commission the inverter.

The specific commissioning procedures are as follows:

- a) Make sure that the output MCBs of all UPSs in the parallel system are open, and then close the external input MCB of each UPS in the parallel system, the UPS is powered on at the same time. If 1 + 1 parallel POD is configured, close the corresponding input MCB and bypass MCB. At the same time, close the corresponding

output MCB of the other UPS which is being tested, and make sure that the corresponding output MCB of the other UPS is open.

**Warning**

After the UPS external output MCB or POD output MCB is closed, the UPS output terminal block, POD output terminal block and load will be live, pay attention to personnel safety to avoid electric shock. Note whether it is safe to feed power to load.

- b) The LCD displays the self check screen, and the alarm indicator (red) and run indicator (green) are on at the same time for about five seconds.
- c) After the rectifier has been in normal operation state for about 30 seconds, the rectifier start-up is finished.
- d) Set the parallel parameters for each UPS. Note whether there is an alarm of 'Parallel comm. Fail', if yes, clear the fault according to Table 4-5 in *Liebert ITA2 5kVA~20kVA User Manual*. Carry out the following procedures if the UPS is running normally.
- e) Press the power button of one UPS for 2 seconds, if 1 + 1 parallel POD is configured, press the power button of the UPS which is being tested in the parallel system, then press the Enter key to start the UPS. The run indicator (green) will blink, after 20 seconds, the inverter will start, and the run indicator will turn on, if 1 + 1 parallel POD is configured, the other UPS will display no redundancy in parallel, ignore the prompt at the moment.
- f) If the battery is not connected, the alarm indicator will be solid on, and the buzzer will beep every seconds. If the battery is connected, the alarm indicator will turn off.
- g) If the UPS is working normally, press the power button for two seconds to turn off the inverter.
- h) Repeat the preceding step a) ~ step g) to power on and commission the inverter of other UPSs respectively.

**Note**

Carry out the parallel commissioning after each UPS is working normally.

2. After confirming that the inverter of each UPS is normal, commission the parallel system, the specific procedures are as follows:

- a) Close the external output MCB and input MCB of each UPS, and all UPSs are powered on at the same time. After the start of the rectifier is finished, press the power button of one UPS for two seconds, the run indicator (green) will be on. Measure whether the inverter output voltage is normal. If the 1 + 1 parallel POD is configured, close the corresponding input MCB, bypass MCB and output MCB of the POD.
- b) Start the inverter of the second UPS, check whether there is an alarm on the LCD, and confirm that the UPS parallel works normally.
- c) Follow the methods to start the inverter of the third or the fourth UPS to connect the UPS into the parallel system.

**Warning**

1. During the parallel power-on, confirm that the external output MCB of each UPS has been closed, and that all the inverter output of the UPSs are connected parallelly.
2. During the parallel power-on, confirm that the system is working normally, and then feed power to the load, to avoid load power failure.

3. If the user needs to add one UPS in the parallel system, follow the commissioning procedures below:
- a) Check and confirm that the power distribution mode, each power cable and signal cable of the added UPS are well connected without short circuit. Check that the battery installation and cables connection are correct without short circuit, and that the positive and negative are correct.
 - b) Repeat steps a) to h) in Part 1 to complete the single unit commissioning of the added UPS. Then completely power off the UPS.
 - c) Ensure that the connection of power cable and signal cable is reliable.
 - d) For any online UPS, enter the interface shown in Figure 4-1. Set the system parallel No. from 'N' to 'N+1', then click the 'Sync parallel parameters'.
 - e) Close the external I/O switches of the added UPS, normally start the inverter after the rectifier start-up. Then check that the LCD has no alarm, and that the UPS parallel system works normally.

**Note**

1. For 1+1 parallel system, when one UPS is faulty and needs to be replaced on line, the above operation steps are available too. The difference is no need to change parallel No., just click the 'Sync parallel parameters' for the online UPS.
2. Clicking the 'Sync parallel parameters' to achieve the synchronization of the items in parallel settings interface, and the parameters will affect the parallel system. The user should manually set other parameters according to actual needs.
3. When adding a single unit in the parallel system, first ensure the parallel cables connection is correct, then power on the single unit.

Appendix 1 LCD Parameters Setting

Menu	Item	Setting range	Default setting	
System	Auto restart	Disable, Enable	Enable	
	Auto restart delay	0~999 seconds	10; Single unit only	
	Guaranteed shutdown	Disable, Enable	Disable	
	Remote control	Disable, Enable	Enable	
	Remote power on delay	0~999 seconds	0	
	Remote shutdown delay	0~999 seconds	0	
	Redundant	NO, YES	YES	
	LBS select	Disable, Master, Slave	Disable	
	IT system compatibility	Disable, Enable	Disable	
	Dry contact 1 (Output)	Low battery, On bypass, On battery, UPS fault	Low battery	
	Dry contact 2 (Output)	Low battery, On bypass, On battery, UPS fault	UPS fault	
	Dry contact 3 (Input)	Battery mode shutdown, Any mode shutdown, Maintain mode	Maintain mode	
	Dry contact 4 (Input)	Battery mode shutdown, Any mode shutdown, Maintain mode	Maintain mode	
Output	Voltage selection	220V, 230V, 240V	220V	
	Startup on bypass	Disable, Enable	Disable	
	Frequency selection	Auto, BypEna; Auto, BypDisa; 50Hz, BypDisa; 60Hz, BypDisa	Auto, BypEna	
	Inverter sync range	±0.5Hz, ±1.0Hz, ±2.0Hz, ±3.0Hz, ±4.0Hz, ±5.0Hz	±3.0Hz	
	Bypass upper limit	+10%, +15%, +20%	+20%	
	Bypass lower limit	-10%, -20%, -30%, -40%	-40%	
	Bypass frequency range	±5Hz, ±10Hz	±10Hz	
	Run mode	Normal, ECO mode	Normal	
	ECO voltage range	±5%, ±10%, ±15%	±10%	Appear only when the 'Run mode' is set to 'ECO mode'
	ECO frequency range	±1Hz, ±2Hz, ±3Hz	±3Hz	
	ECO requalification time	5, 15, 30 (min)	30	
Output phase No.	1 phase, 3 phases	1 phase		
Parallel	Voltage selection	220V, 230V, 240V	220V	
	Frequency selection	Auto, BypEna; Auto, BypDisa; 50Hz, BypDisa; 60Hz, BypDisa	Auto, BypEna	
	Run mode	Normal, ECO mode	Normal	
	Redundant	NO, YES	YES	
	System parallel No.	1~4	1	
	Output phase No.	1 phase, 3 phases	1 phase	
	Sync parallel parameters	Button	Button	

Menu	Item	Setting range	Default setting
Battery	Shared battery	Disable, Enable	Disable
	Local/Parallel battery total Ah	7~3000Ah	9Ah
	External battery cabinet count	Auto test, 0~10	Auto test
	Low battery time	2~30 (min)	2
	Battery replaced time	YYYY-MM-DD HH:MM:SS	2000-01-01 0:00:00
	Battery test interval	Disable, 8 weeks, 12 weeks, 16 weeks, 20 weeks, 26 weeks	Disable
	Battery test weekday	Sunday, Monday, Tuesday, Wednesday, Thursday, Friday, Saturday	Wednesday
	Battery test time	HH:MM:SS	0:00:00
	Battery series	12, 16, 20	16
	Discharge protect time	1~4320 (min)	4320
	Equal charge enable	YES, NO	NO
	Temperature compensation	Disable, Enable	Disable
	Replace battery	Button	Button
Outlet	Turn on outlet		Appear only when outlet off
	Turn off outlet		Appear only when outlet on
	Reboot outlet		Appear only when outlet on
	Turn off when UPS overload on battery	YES, NO	NO
	Turn off when UPS on battery for	0~4320 (min)	2
	Turn off when backup time less than	0~4320 (min)	0
	Turn off when battery capacity less than	20~80%	30%
	Turn on when power returns for	0~4320 (min)	0
Monitor	Language	English, Chinese	English
	Date	YYYY-MM-DD	2016-10-01
	Time	HH:MM:SS	00:00:00
	Display orientation	Auto-rotate, Horizontal, Vertical	Auto-rotate
	Audible alarm	Enable, Disable	Enable
	Control port protocol	Modbus, Sensor	Sensor
	Modbus address	1~128	1
	IPv4 address	ddd.ddd.ddd.ddd ('d' is a decimal number)	192.168.1.10
	Subnet mask		255.255.255.0
	Gateway address		192.168.1.1
Change settings password	The password is numeric only and can be set from 0 to 9. The password length is 6	111111	

Appendix 2 Hazardous Substances And Content

Parts	Hazardous substances					
	Plumbum	Hydrargyru	Cadmium	Chrome ⁶⁺	PBB	PBDE
	(Pb)	(Hg)	(Cd)	(Cr (VI))	(PBB)	(PBDE)
Cables	×	○	○	○	○	○
<p>This table is made following the regulation of SJ/T 11364.</p> <p>○: Means the content of the hazardous substances in all the average quality materials of the parts is within the limits specified in GB/T 26572</p> <p>×: Means the content of the hazardous substances in at least one of the average quality materials of the parts is outside the limits specified in GB/T 26572</p>						
Applicable scope: Liebert® ITA2™ 5kVA/6kVA POD						